

# PCD T-SLOT CUTTERS

FOR PROFILING ON CNC ROUTER AND MACHINING CENTERS

R.H. No.	L.H. No.	Diameter	Diameter	Z	Cutting Length		Overall Length	
		Ø D max.	Ø D min.		L1	Y		L2
TS-3204	TS-3206	1-1/4"	3/8"	2+1	.250"	1/16"	1/2"	2-3/8"
TS-3205	TS-3207	1-1/4"	3/8"	2+1	.355"	1/16"	1/2"	2-3/8"
TS-3505	TS-3507	1-3/8"	3/8"	2+1	.250"	1/16"	1/2"	2-3/8"
TS-3508	TS-3509	1-3/8"	3/8"	2+1	.355"	1/16"	1/2"	2-3/8"

\* ADDITIONAL DESIGNS AVAILABLE ON REQUEST  
(DIFFERENT SHANK LENGTH AND DIA, Z=2+2)

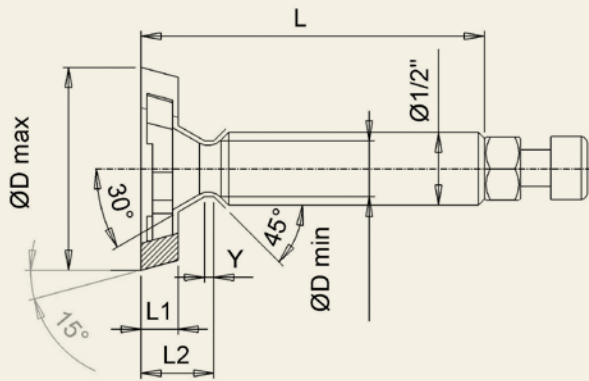

R.H. No.	L.H. No.	Diameter	Diameter	Z	Cutting Length		Shank Dia.	Overall Length
		Ø D1	Ø D2		B2	B1		
TSS-3005	TSS-3007	1 3/16"	3/8"	2+1	1/4"	5/8"	1/2"	2 3/8"
TSS-3205	TSS-3207	1 1/4"	3/8"	2+1	1/4"	3/4"	1/2"	2 1/2"
TSS-3505	TSS-3507	1 3/8"	3/8"	2+1	1/4"	3/4"	1/2"	2 1/2"
TSS-3508	TSS-3509	1 3/8"	3/8"	2+1	3/8"	7/8"	1/2"	2 1/2"

\* ADDITIONAL DESIGNS AVAILABLE ON REQUEST  
(DIFFERENT SHANK LENGTH AND DIA, Z=2+2)

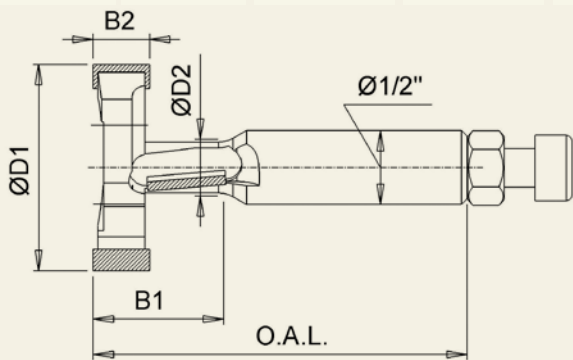

- SLOTTING IN MDF WITH OR WITHOUT COATING FOR T-SLOT DISPLAY WALLS IN ONE WORKING STEP
- WITH TWO TIPS ON THE WING AND ONE TIP ON THE NECK
- SHEAR ANGLE LEADS FOR OPTIMUM EDGE QUALITY
- MAX RPM: 24,000

