

# Routing

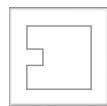

Grooving & Sizing

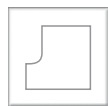

Profiling & Chamfering



Jointing & Rebating



Carving

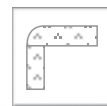

Corian



## Rebating Bit

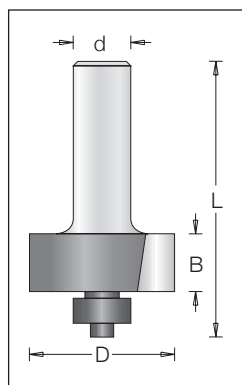

øD	B	Code No.	t	L	ød	
24.0	12.7	1140 05 3	4.0	53.0	6	B
	12.7	1140 01 3	9.5	51.5	6	A
31.8	12.7	1140 01 5	9.5	55.0	8	A
	12.7	1140 01 9	9.5	61.0	12	A
35.0	12.7	1140 06 3	11.1	52.0	6	A
	12.7	1140 06 5	11.1	55.0	8	A
	12.7	1140 06 9	11.1	61.3	12	A

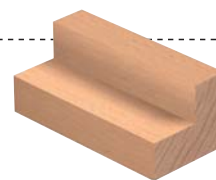

⚠ 6mm shank can be supplied with 1/4" shank.  
12mm shank can be supplied with 1/2" shank.

### Spare Parts:



A. Ball Bearing  
#191 007 0  
4.7x12.7 x5



B. Ball Bearing  
#191 005 0  
6.3x16x5

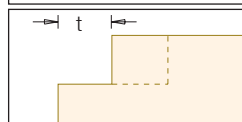

## Rebating Bit

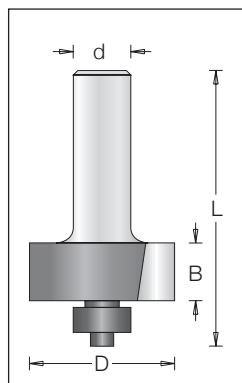

øD	B	Code No.	L	ød
35	12.7	1144 06 3	52.0	6
	12.7	1144 06 5	55.0	8
	12.7	1144 06 9	61.3	12

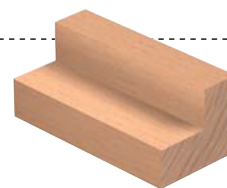

⚠ 6mm shank can be supplied with 1/4" shank.  
12mm shank can be supplied with 1/2" shank.

### Spare Parts:



A. Ball Bearing  
#191 004 0  
9.5x4.7x3



B. Ball Bearing  
#191 007 0  
12.7x4.7x5



C. Ball Bearing  
#191 006 0  
16x4.7x5



D. Ball Bearing  
#191 150 0  
19x4.7x5

- A t=12.7
- B t=11.1
- C t=9.5
- D t=8

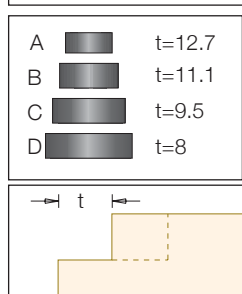

## Super - Rebate

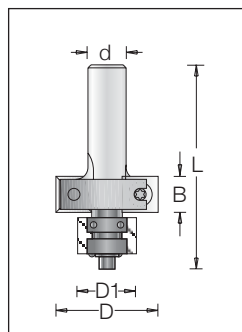

øD	B	Code No.	L	ød	t
38.1	12.0	1143 01 8	66	12	12

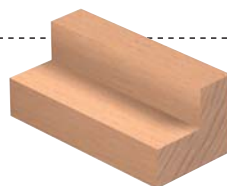

⚠ Can be supplied with 1/2" shank.

### Spare Parts:



T.C. Blade  
#310 121 2  
12x12x1.5



Ball Bearing  
#191 003 0  
6.3x12.7x4.7



Washer  
#195 001 0  
3.25x7.5x1.0



Spacer  
#192 027 0  
6.5x9.5x2.2



Allen screw  
#193 004 0  
NC 5-1/2



Torx screw  
#193 148 2  
M4-0.7



Allen key  
1940010  
3/32



Allen key  
1941015  
T15

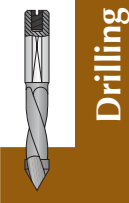
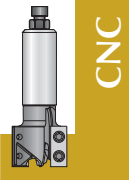



# Routing

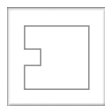

Grooving & Sizing



Profiling & Chamfering



Jointing & Rebating



Carving

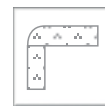

Corian



## Super - Rebate

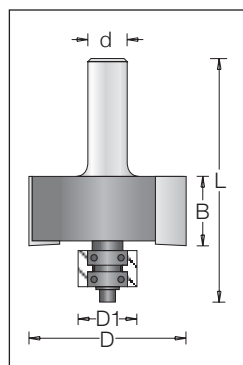

øD	B	Code No.	L	ød	t
50.8	22.5	1146 10 9	78	12	15.9

⚠ Can be supplied with 1/2" shank.

### Spare Parts:



Ball Bearing  
#191 003 0  
6.3x12.7x4.7



Washer  
#195 001 0  
3.25x7.5x1.0



Spacer  
#192 027 0  
6.5x9.5x2.2



Allen screw  
#193 004 0  
NC 5-1/2



Allen key  
1940010  
3/32

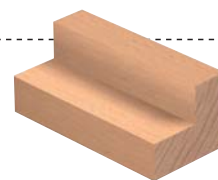

Sawing

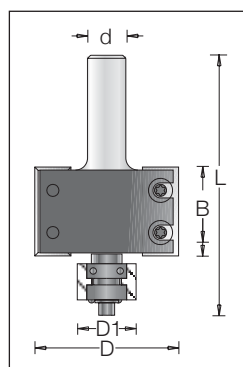

øD	B	Code No.	L	ød	t
50.8	29.5	1143 10 9	84	12	15.9

⚠ Can be supplied with 1/2" shank.

### Spare Parts:



T.C. Blade  
#310 723 0  
12x29.5x1.5



Ball Bearing  
#191 003 0  
6.3x12.7x4.7



Washer  
#195 001 0  
3.25x7.5x1.0



Spacer  
#192 027 0  
6.5x9.5x2.2



Allen screw  
#193 004 0  
NC 5-1/2



Allen screw  
#193 148 2  
M4-0.7



Allen key  
1940010  
3/32



Allen key  
1941015  
T15

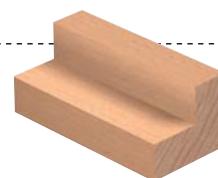

CNC

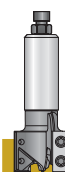

Cutting

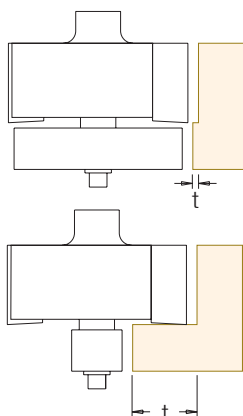

### Selection of rings

øD1	Code No.	t
47.6	1929 90 0	1.6
44.4	1929 89 0	3.2
41.3	1929 88 0	4.7
38.9	1929 95 0	5.9
38.1	1929 87 0	6.3
34.9	1929 86 0	7.9
32.5	1929 94 0	9.1
31.7	1929 85 0	9.5
28.6	1929 84 0	11.1
27.0	1929 93 0	11.9
25.4	1929 83 0	12.7
22.2	1929 82 0	14.3
20.6	1929 92 0	15.1
19.0	1929 81 0	15.9
15.9	1929 80 0	17.4
14.3	1929 91 0	18.2



14.3	22.2	31.7	38.9
15.9	25.4	32.5	41.3
19.0	27.0	34.9	44.4
20.6	28.6	38.1	47.6

Drilling



Routing



Custom Tooling

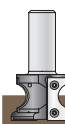

# Routing

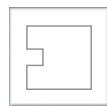

Grooving & Sizing

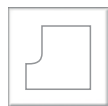

Profiling & Chamfering



Jointing & Rebating



Carving

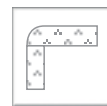

Corian



## Dovetail Bit

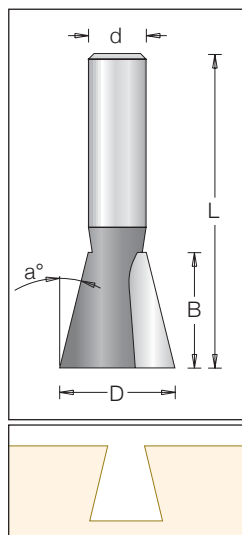

øD	a	B	Code No.	L	ød
6.3	7°	8.0	1040 15 3 *	63.5	6
	7°	8.0	1040 15 5 *	44.0	8
8.0	9°	9.5	1040 24 3 *	63.5	6
	9°	9.5	1040 24 5 *	42.0	8
9.5	9°	9.5	1040 01 3	42.0	6
	9°	9.5	1040 01 5	47.0	8
12.7	14°	12.7	1040 04 3	44.5	6
	14°	12.7	1040 04 5	49.0	8
13.2	13°	13.0	1040 85 3	55.5	6
15.9	7°	15.9	1040 07 3	44.5	6
6.3	7°	8.0	1040 15 9 *	63.5	12
	9°	9.5	1040 01 9	54.0	12
12.7	14°	12.7	1040 04 9	60.0	12
14.0	5°	19.1	1040 36 9	64.0	12
15.9	7°	15.9	1040 07 9	58.0	12
	7°	22.2	1040 10 9	65.0	12
19.1	5°	25.4	1040 37 9	68.0	12
	7°	22.2	1040 13 9	65.0	12
22.2	14°	19.1	1040 16 9	65.0	12
	7°	22.2	1040 19 9	60.0	12
25.4	14°	22.2	1040 22 9	67.0	12
	14°	25.4	1040 25 9	69.5	12
14.7	12°	14.3	1040 05 3	58.0	6
	12°	14.3	1040 05 5	61.0	8

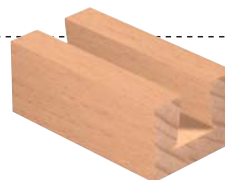

Sawing



CNC

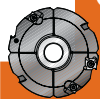

Cutting



\* Solid Carbide

6mm shank can be supplied with 1/4" shank.  
12mm shank can be supplied with 1/2" shank.

## Spurs Dovetail Bit

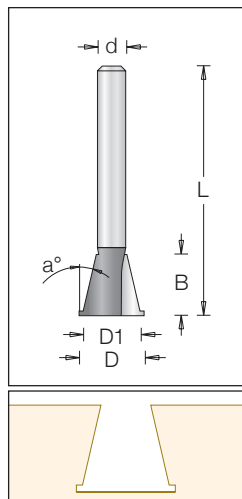

øD	øD1	a	Code No.	B	L	ød
14.3	12.7	13°	1040 86 3	13.5	55	6
	12.7	13°	1040 86 5	13.5	58	8

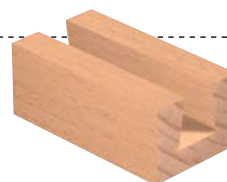

Can be supplied with 1/4" shank.

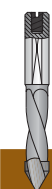

Drilling

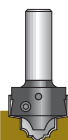

Routing

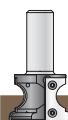

Custom Tooling



# Routing

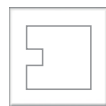

Grooving & Sizing

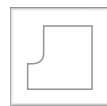

Profiling & Chamfering

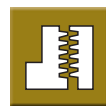

Jointing & Rebating



Carving

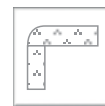

Corian



Index

## Dovetail Bit

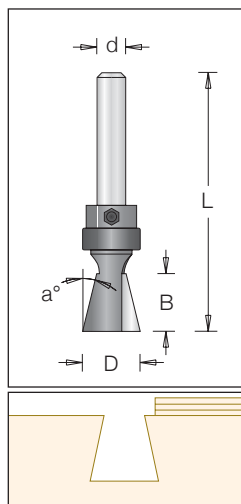

øD	a	B	Code No.	L	ød	
12.7	14°	12.7	1042 04 3	56	6	A
14.6	12°	14.0	1042 05 3	60	6	A
8.7	7°	9.5	1042 51 3	58	6	B

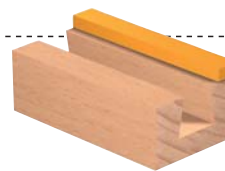

⚠ Can be supplied with 1/4" shank.

### Spare Parts:



A. Ball Bearing  
#191 007 0  
12.7x6.3x4.7



B. Ball Bearing  
#191 005 0  
16x6.3x5

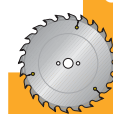

Sawing



CNC

## Butterfly Spline Bit

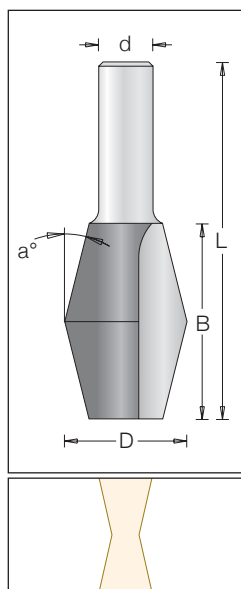

øD	a	B	Code No.	L	ød
28	14°	46	1670 01 9	84	12

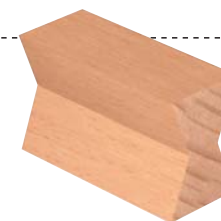

⚠ Can be supplied with 1/2" shank.  
Use these cutters in conjunction with our 14° dovetail bits Code No.: 1040 04 3, 1040 03 9, 1040 16 9, 1040 22 9, 1040 25 9.

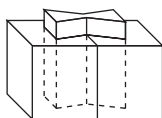

Cutting

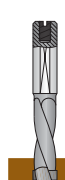

Drilling

## Locking Drawer Glue Joint

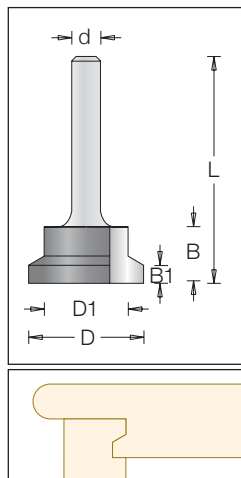

øD	øD1	Code No.	B	B1	L	ød
19.1	12.2	1490 01 3	12.7	4	49	6
25.4	18.5	1490 03 3	12.7	4	49	6
	18.5	1490 03 9	12.7	4	49	12

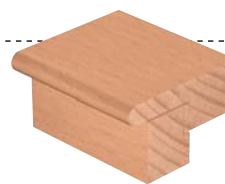

⚠ 6mm shank can be supplied with 1/4" shank.  
12mm shank can be supplied with 1/2" shank.



Routing

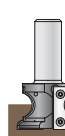

Custom Tooling

# Routing



Grooving & Sizing

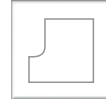

Profiling & Chamfering

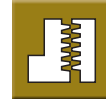

Jointing & Rebating



Carving



Corian



## Glue Joint Bit

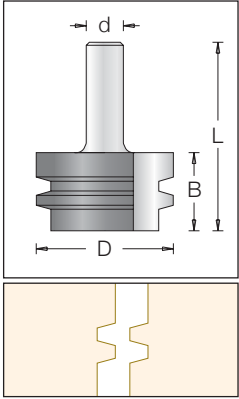

øD	B	Code No.	L	ød
47	28	1490 13 9	66	12

⚠ Can be supplied with 1/2" shank.

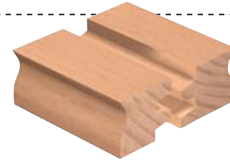

## 45° Lock Mitre Joint Bit

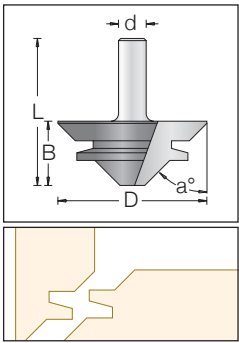

øD	a	B	Code No.	L	ød	n
38.1	45°	12.7	1490 07 3	41.3	6	
41.7	45°	16.0	1490 05 3	44.6	6	
44.5	45°	20.0	1490 06 9	58.0	12	
67.0	45°	29.5	1490 04 9	77.5	12	18,000

⚠ 6mm shank can be supplied with 1/4" shank.  
12mm shank can be supplied with 1/2" shank.

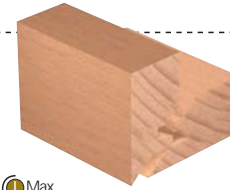

Max. RPM

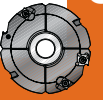
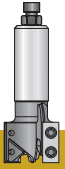

## Wedge & Tongue Bit

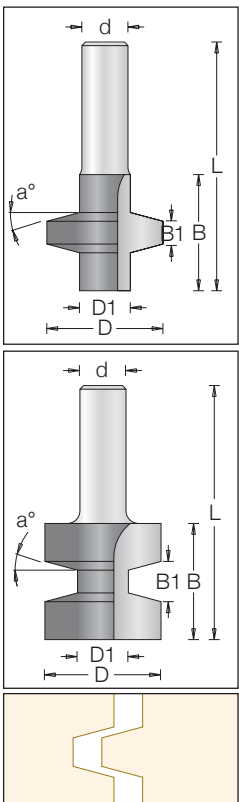

øD	øD1	Code No.	a	B	B1	L	ød
Set No.		1490 50 9					
32.0	14	1490 51 9	15°	32	6.5	70	12
31.5	14	1490 52 9	15°	32	11.1	70	12

⚠ Can be supplied with 1/2" shank.

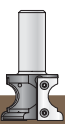
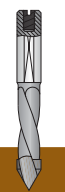
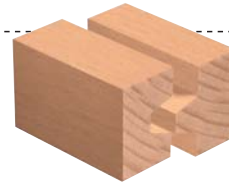



# Routing

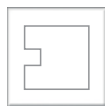

Grooving & Sizing

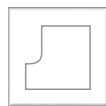

Profiling & Chamfering

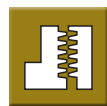

Jointing & Rebating



Carving

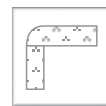

Corian



Index

## Tongue & Groove Bevel Set

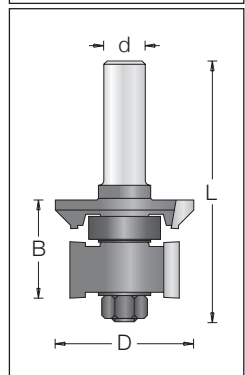
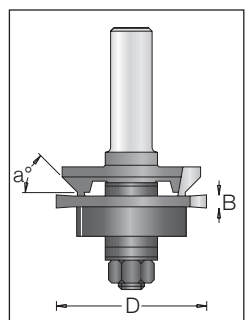

	øD	a	B	Code No.	L	ød
Complete	42.5	45°	30.5	1681 00 9	80	12
Profile Cutter	42.5	45°	9.0	1681 01 0		
rebating Cutter	33.5		17.5	1680 01 0		
Groover	46.0		4.0	1421 04 0		

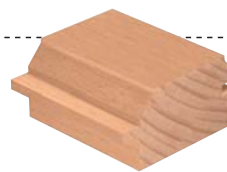

Can be supplied with 1/2" shank.

### Spare Parts:



Arbor & Nut  
#190 005 9  
L=80



Ball Bearing  
#191 013 0  
8x22x7



Ball Bearing  
#191 945 0  
8x33.5x8.6



Washer  
#192 011 0  
1X16



Spacer  
#192 015 0  
3X16



Spacer  
#192 011 0  
1X16



Spacer  
#192 013 0  
0.5X16



Spacer  
#192 012 0  
0.4X16



Spacer  
#192 100 0  
0.1X16



Spacer  
#192 050 0  
0.05X16



Sawing



CNC



Cutting

## Tongue & Groove Round Set

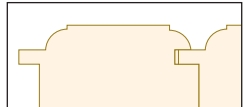
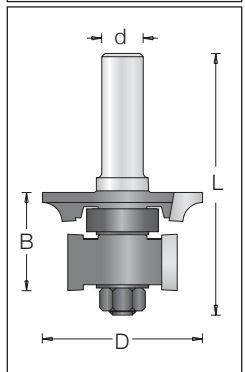
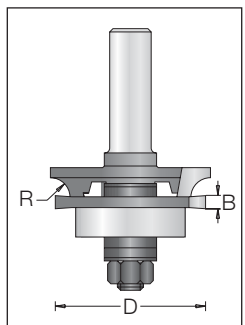

	øD	R	Code No.	B	L	ød
Complete	49.0	6	1682 00 9	30.5	80	12
Profile Cutter	49.0	6	1682 01 0	9.0		
rebating Cutter	33.5		1680 01 0	17.5		
Groover	46.0		1421 04 0	4.0		

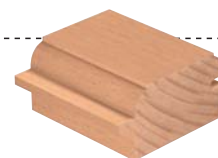

### Spare Parts:



Arbor & Nut  
#190 005 9  
L=80



Ball Bearing  
#191 013 0  
8x22x7



Ball Bearing  
#191 945 0  
8x33.5x8.6



Washer  
#192 011 0  
1x16



Spacer  
#192 015 0  
3x16



Spacer  
#192 011 0  
1x16



Spacer  
#192 100 0  
0.1x16



Spacer  
#192 050 0  
0.05x16



Spacer  
#192 013 0  
0.5x16



Spacer  
#192 012 0  
0.4x16

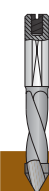

Drilling

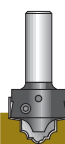

Routing



Custom Tooling

# Routing

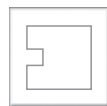

Grooving & Sizing

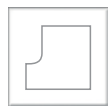

Profiling & Chamfering



Jointing & Rebating



Carving



Corian



## Slotting Cutter (Flat installation)

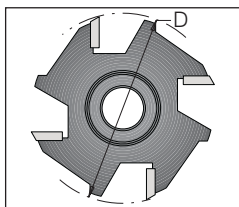
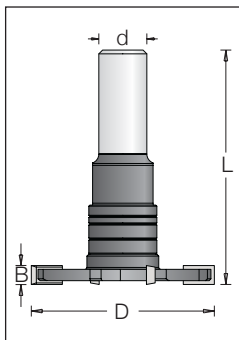

øD	Set No.	B	Z	L	ød	Cutter Code No.
40	108 610 8	10	4	61	12.7	108 610 0
	555 037 8	2	4	61	12.7	555 037 0
	108 651 8	2.5	4	61	12.7	108 651 0
	108 652 8	3	4	61	12.7	108 652 0
	108 653 8	4	4	61	12.7	108 653 0
50	108 654 8	5	4	61	12.7	108 654 0
	108 655 8	6	4	61	12.7	108 655 0
	555 080 8	7	4	61	12.7	555 080 0
	557 065 8	8	4	61	12.7	557 065 0
	557 062 8	9.5	4	61	12.7	557 062 0
	557 095 8	11	4	61	12.7	557 095 0

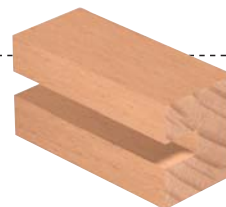

Sawing

### Spare Parts:



Arbor

#190 063 8  
L=61xM12



Washer

#192 134 0  
18x12x4



Washer

#192 132 0  
18x12x2



Washer

#192 133 0  
18x12x3

## Slotting Cutter

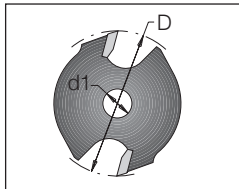
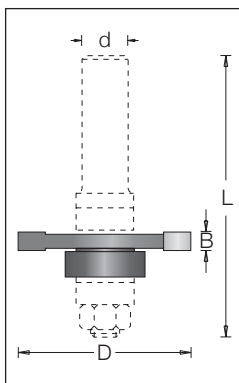

øD	ød1	B	Code No.
40	6.35	1.5	1083 01 0
	6.35	2.0	1083 02 0
	6.35	2.5	1083 03 0
	6.35	3.0	1083 04 0
	6.35	4.0	1083 05 0
	6.35	5.0	1083 06 0
	6.35	6.0	1083 07 0
	6.0	1.5	1082 01 0 *
	6.0	2.0	1082 02 0 *
	6.0	2.5	1082 03 0 *
	6.0	3.0	1082 04 0 *
	6.0	4.0	1082 05 0 *
	6.0	5.0	1082 06 0 *
	6.0	6.0	1082 07 0 *



Cutting



The Code No. refers to slotting cutters only. If you wish to order slotting cutters assembled on the arbor, change the last digit of the catalogue number according to the following arbor shaft sizes: 3=6.0mm, 4=1/4", 5=8.0mm, 8=1/2", 9=12mm.

### Spare Parts:



Arbor & Nut  
#190 010 3  
L=55



Arbor & Nut  
#190 010 5  
L=58



Arbor & Nut  
#190 010 9  
L=64



Arbor & Nut \*  
#190 020 3  
L=52



Arbor & Nut \*  
#190 020 5  
L=57



Ball Bearing  
#191 005 0  
16x6.3x5



Ball Bearing \*  
#191 012 0  
19x6x6

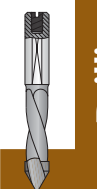

Drilling

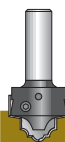

Routing



Custom Tooling



# Routing

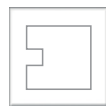

Grooving & Sizing

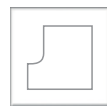

Profiling & Chamfering

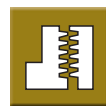

Jointing & Rebating



Carving

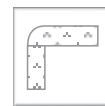

Corian

## Slotting Cutter

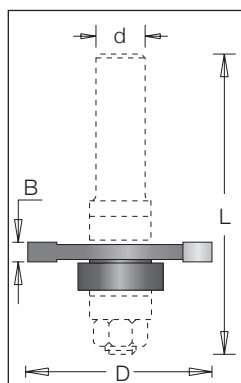
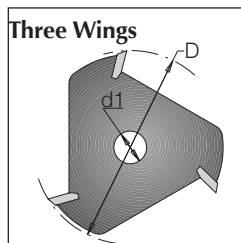
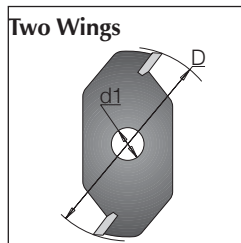

	øD	ød1	B	Code No.
47.6		7.94	1.5	1080 51 0
		7.94	2.0	1080 54 0
		7.94	2.5	1080 57 0
		7.94	3.0	1080 60 0
		7.94	4.0	1080 63 0
		7.94	5.0	1080 67 0
	7.94	6.0	1080 70 0	

	øD	ød1	B	Code No.
47.6		7.94	1.5	1080 73 0
		7.94	2.0	1080 76 0
		7.94	2.5	1080 79 0
		7.94	3.0	1080 82 0
		7.94	4.0	1080 85 0
		7.94	5.0	1080 88 0
	7.94	6.0	1080 91 0	



The Code No. refers to slotting cutters only. If you wish to order slotting cutters assembled on the arbor, change the last digit of the catalogue number according to the following arbor shaft sizes: 3=6.0mm, 4=1/4", 5=8.0mm, 8=1/2".

### Spare Parts:



Arbor & Nut  
#190 004 3  
L=67



Arbor & Nut  
#190 004 5  
L=70



Arbor & Nut  
#190 004 9  
L=76



Ball Bearing  
#191 013 0  
22x8x7

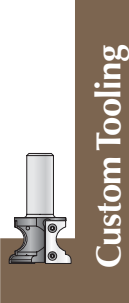
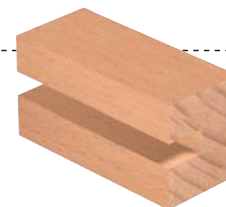



# Routing

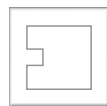

Grooving & Sizing

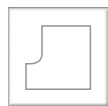

Profiling & Chamfering

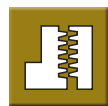

Jointing & Rebating



Carving

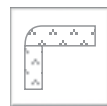

Corian



Index

## Quadriset - Slotting Cutter

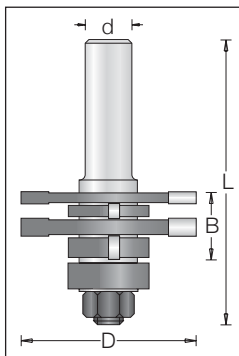

	øD	B	Code No.	L	ød
Complete	47.6	18.0	1084 00 9	76.2	12.00
Cutter A	47.6	3.2	1080 10 0		7.94
Cutter B	47.6	4.0	1080 13 0		7.94
Cutter C	47.6	4.8	1080 16 0		7.94
Cutter D	47.6	6.3	1080 19 0		7.94

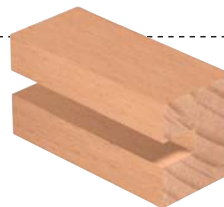

**⚠** Recommended combination for varying cutting width. If intermediate cutting widths are required, shims are added or removed accordingly.

### Spare Parts:



Arbor & Nut  
#190 006 9  
L=76



Ball Bearing  
#191 013 0  
8x22x7



Washer  
#192 011 0  
x15



Spacer  
#192 011 0  
1x16



Spacer  
#192 013 0  
0.5x16



Spacer  
#192 100 0  
0.1x16

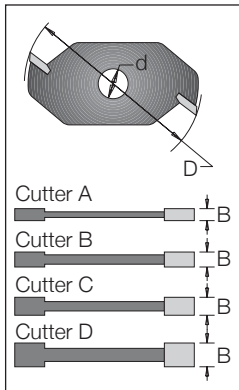

Width mm	5.7	6	7	8	9	10	11	12	13	14	15	16	17	18
Cuttter	A	A	A	A	C	C	C	B	B	A	A	A	A	A
Shims		0.3	1.0	0.7	0.4	1.4	2.4	0.4	0.4	1.0	0.4	1.4	1.4	1.5
Cuttter	B	B	C	D	D	D	D	C	C	B	B	B	B	B
Shims								1.0	1.4	0.3	1.3	1.3	1.3	1.8
Cuttter								D	D	C	C	C	C	C
Shims										1.0	1.0	1.0	2.0	2.5
Cuttter										D	D	D	D	D

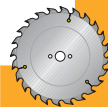

Sawing

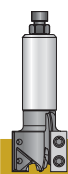

CNC

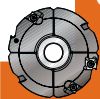

Cutting

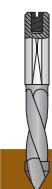

Drilling

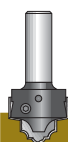

Routing

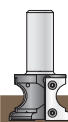

Custom Tooling

# Adjustable Width Router

## Routing

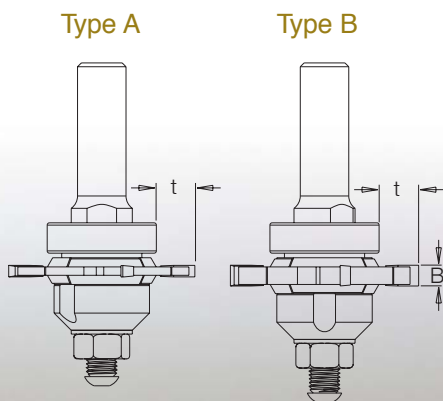
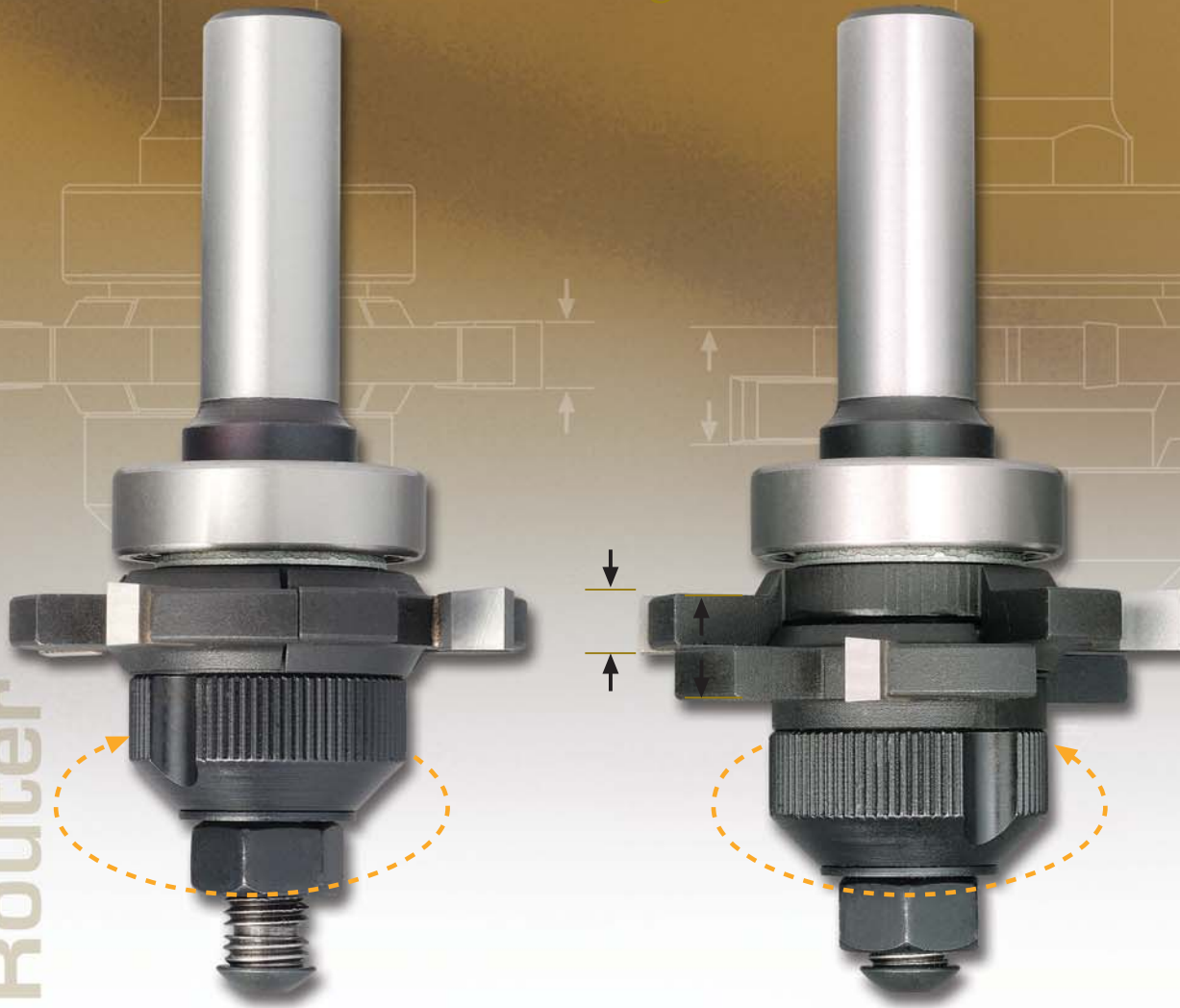

PAT. PEND. No. 149909IL

## D-SLOTTER™

### Adjustable Slotting System

- Easy and simple adjustment.
- Continuous width adjustment.
- Shorter setup time.
- Laser etched scale of 0.05mm.

Type	D	B	Code No.	L	t	d
A	50	3.0- 5.5	108 460 9	84.6	10.7	12
A	50	3.0- 5.5	108 460 5	78.5	10.7	8
B	50	5.5-10.0	108 465 9	88.9	10.7	12
B	50	5.5-10.0	108 465 5	82.8	10.7	8

Index

Sawing



CNC



Cutting

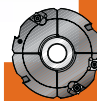

Drilling



Routing



Custom Tooling

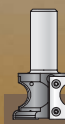

# Routing

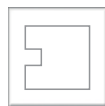

Grooving & Sizing

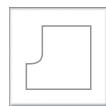

Profiling & Chamfering

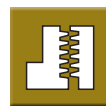

Jointing & Rebating



Carving



Corian



Index

## Combi Joint Set

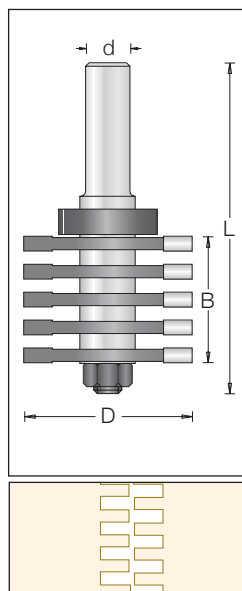

øD		Code No.	B	L	ød
47.6	Complete	1089 01 9	36	96	12
47.6	Cutters	1080 85 0	36		12

### Spare Parts:



Delrin Set  
#191 950 0  
8x28x8.5



Delrin Set  
#195 951 0  
8x29x8.5



Delrin Set  
#195 952 0  
8x34x8.5



Arbor & Nut  
#190 009 9  
L=96



Washer  
#192 011 0  
8x15.9x1



Spacer  
#192 029 0  
5.3x16



Spacer  
#192 013 0  
0.5x16



Spacer  
#192 100 0  
0.1x16



Spacer  
#192 050 0  
0.05x16

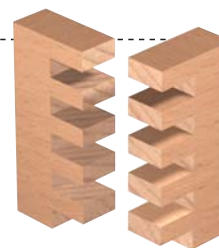

Sawing

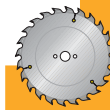

CNC

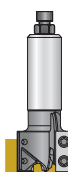

## Two Wings Finger Jointer Set

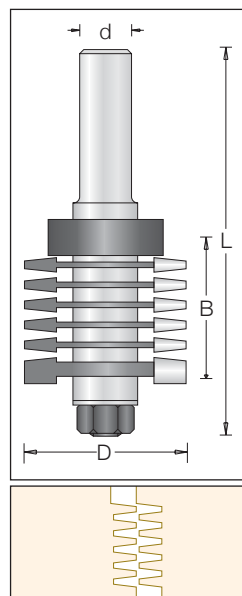

	øD	B	Code No.	L	ød
Complete	39.5	33.0	1089 00 9	96	12
Cutter A (x5)	39.5	1.85	1089 03 0		
Cutter B (x1)	39.1	5.50	1089 20 0		

⚠ Can be supplied with 1/2" shank.

### Spare Parts:



Arbor & Nut  
#190 040 9  
L=96



Ball Bearing  
#191 016 0  
8x28x7



Washer  
#192 011 0  
8x16x1.0



Spacer  
#192 016 0  
6x16



Spacer  
#192 020 0  
3.4x16



Spacer  
#192 011 0  
1x16



Spacer  
#192 013 0  
0.5x16



Spacer  
#192 100 0  
0.1x16



Spacer  
#192 050 0  
0.05x16

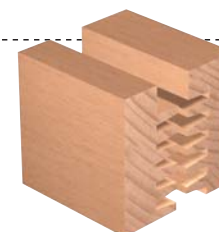

Cutting

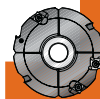

Drilling



Routing



Custom Tooling

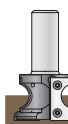



# Routing

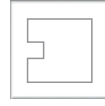

Grooving & Sizing

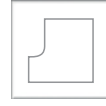

Profiling & Chamfering

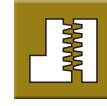

**Jointing & Rebating**



Carving

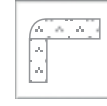

Corian

Index

## Lambs Tongue Sash Bar Set

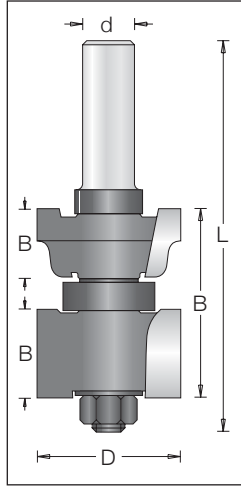

øD		Code No.	B	L	ød	n
35	Complete	1330 20 9	47.0	96	12.0	16,000
35	Profile Cutter	1332 01 0	17.0			
35	Rebating Cutter	1332 04 0	22.0			

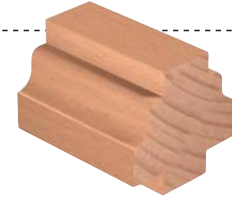

Can be supplied with 1/2" shank.

Max. RPM

### Spare Parts:



Arbor & Nut  
#190 009 9  
L=96



Ball Bearing  
#191 013 0  
8x22x7



Washer  
#192 011 0  
8x16x1.0



Spacer  
#192 016 0  
6x16



Spacer  
#192 015 0  
3x16



Spacer  
#192 013 0  
0.5x16



Spacer  
#192 100 0  
0.1x16



Spacer  
#192 050 0  
0.05x16

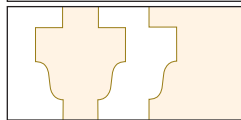
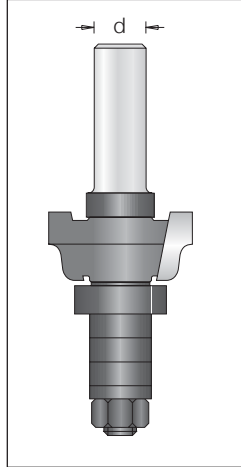

Sawing



CNC

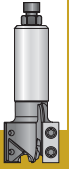

Cutting

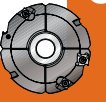

Drilling

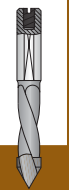

Routing

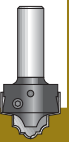

Custom Tooling

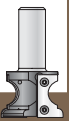

# Routing

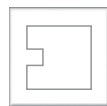

Grooving & Sizing

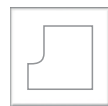

Profiling & Chamfering



Jointing & Rebating

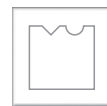

Carving

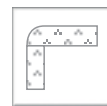

Corian



## Tongue & Groove Cutter Set

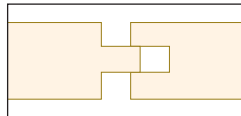
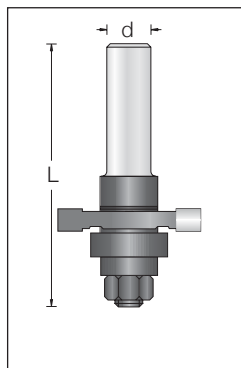
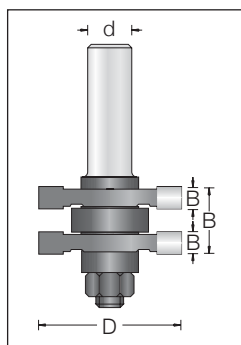

	øD	Code No.	B	L	ød
41	Complete	1434 01 5	19.0	70	8
		1434 01 9 *	19.0	76	12
	Components Groover (x2)	1431 04 0	6.35		

### Spare Parts:



Arbor & Nut  
#190 004 5  
L=70



Arbor & Nut \*  
#190 004 9  
L=76.2



Ball Bearing  
#191 013 0  
8x22x7



Washer  
#192 011 0  
1x16



Spacer  
#192 016 0  
6x16



Spacer  
#192 011 0  
1x16



Spacer  
#192 100 0  
0.05x16

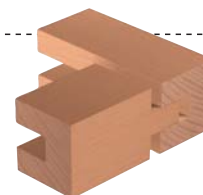

Sawing

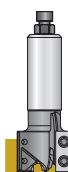

CNC

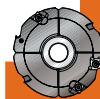

Cutting

## Tongue & Groove - Raised Panel Set

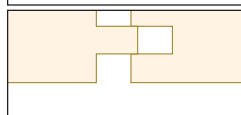
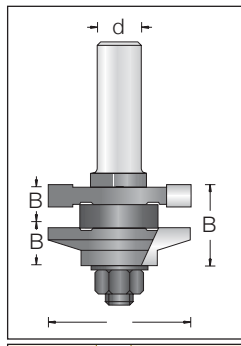
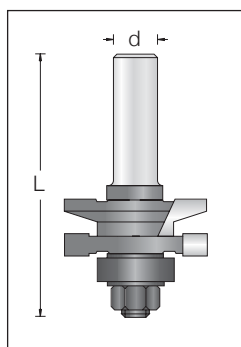

	øD	Code No.	B	L	ød
41	Complete	1433 01 5	22.0	70	8
		1433 01 9 *	22.0	76	12
	Profile Groover	1431 21 0	11.0		
	Groove	1431 04 0	6.3		

### Spare Parts:



Arbor & Nut  
#190 004 5  
L=70



Arbor & Nut \*  
#190 004 9  
L=76



Ball Bearing  
#191 013 0  
8x22x7



Washer  
#192 011 0  
1x16



Spacer  
#192 100 0  
0.1x16



Spacer  
#192 050 0  
0.05x16

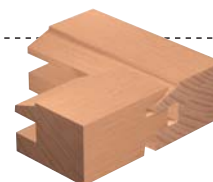

Drilling



Routing

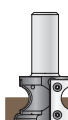

Custom Tooling



# Routing

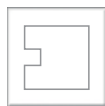

Grooving & Sizing

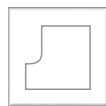

Profiling & Chamfering

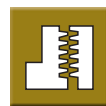

Jointing & Rebating



Carving

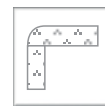

Corian

## Tongue & Groove Classic Set

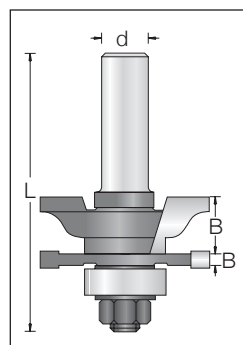

	øD	B	Code No.	L	ød
Complete	46	22	1420 01 5	70.0	8
	46	22	1420 01 9 *	76.0	12
Profile Groover	46	15	1421 01 0		
Groover	46	4	1421 04 0		

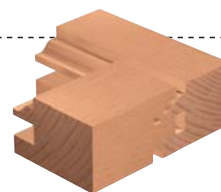

### Spare Parts:



Arbor & Nut  
#190 004 5  
L=70



Arbor & Nut \*  
#190 004 9  
L=76



Ball Bearing  
#191 013 0  
8x22x7



Washer  
#192 011 0  
1x16



Spacer  
#192 100 0  
0.1x16



Spacer  
#192 050 0  
0.05x16

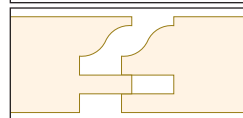
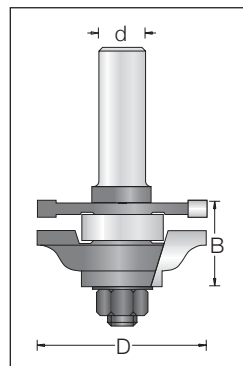

## Tongue & Groove Flat Classic Set

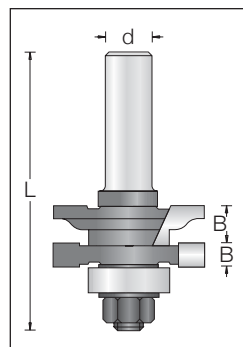

	øD	B	Code No.	L	ød
Complete	41	22.0	1430 01 5	70.0	8
	41	22.0	1430 01 9 *	76.0	12
Profile Cutter	41	11.0	1431 01 0		
Groover	41	6.3	1431 04 0		

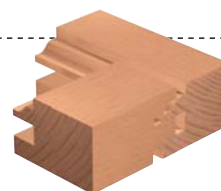

### Spare Parts:



Arbor & Nut  
#190 004 5  
L=70



Arbor & Nut \*  
#190 004 9  
L=76



Ball Bearing  
#191 013 0  
8x22x7



Washer  
#192 011 0  
1x16



Spacer  
#192 100 0  
0.1x16



Spacer  
#192 050 0  
0.05x16

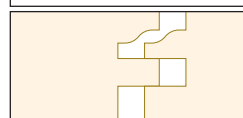
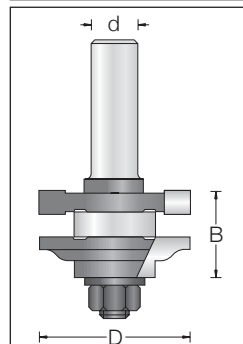

Index

Sawing



CNC

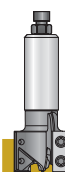

Cutting



Drilling



Routing



Custom Tooling

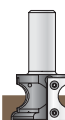

# Routing



Grooving & Sizing

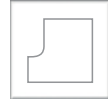

Profiling & Chamfering



Jointing & Rebating



Carving



Corian



Index

## Tongue & Groove Classic Set

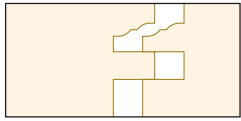
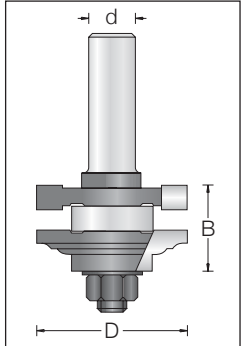
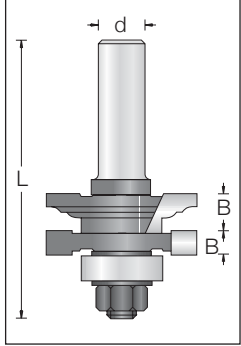

	øD	B	Code No.	L	ød
Complete	41	22.0	1432 01 5	76.2	8
	41	22.0	1432 01 9 *	76.2	12
Profile Cutter	11	11.0	1431 11 0		
Groover	41	6.3	1431 04 0		

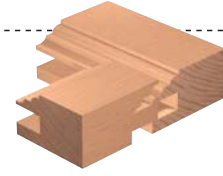

### Spare Parts:



Arbor & Nut  
#190 004 5  
L=70



Arbor & Nut \*  
#190 004 9  
L=76



Ball Bearing  
#191 013 0  
8x22x7



Washer  
#192 011 0  
1x16



Spacer  
#192 100 0  
0.1x16



Spacer  
#192 050 0  
0.05x16

Sawing



CNC

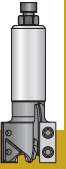

Cutting



Drilling

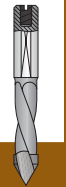

Routing

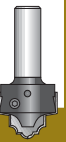

Custom Tooling

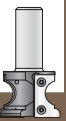



# Routing

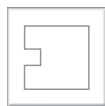

Grooving & Sizing

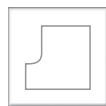

Profiling & Chamfering



Jointing & Rebating



Carving

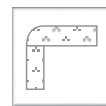

Corian



Index

## Tongue & Groove Classic Set

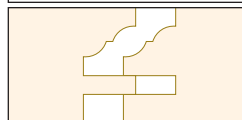
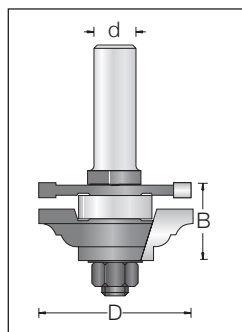
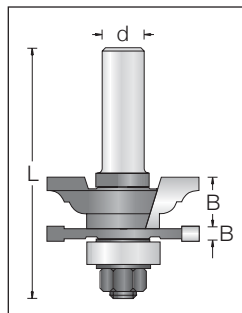

	øD	B	Code No.	L	ød
Complete	46	22.0	1440 01 5	70	8
	46	22.0	1440 01 9 *	76	12
Profile Cutter	46	15.0	1441 01 0		
Groover	46	4.0	1421 04 0		

### Spare Parts:



Arbor & Nut  
#190 004 5  
L=70



Arbor & Nut \*  
#190 004 9  
L=76



Ball Bearing  
#191 013 0  
8x22x7



Washer  
#192 011 0  
1x16



Spacer  
#192 100 0  
0.1x16



Spacer  
#192 050 0  
0.05x16

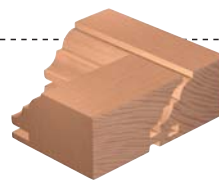

Sawing



CNC



Cutting

## Tongue & Groove Classic Set

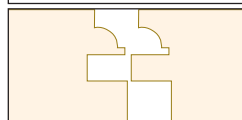
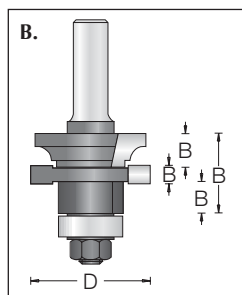
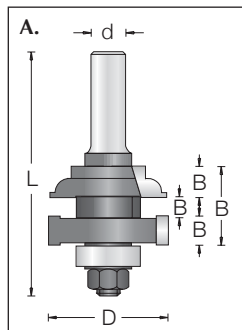

	øD	B	Code No.	L	ød
<b>Complete</b>			1450 04 9		
Cutter A	41.0	27.0	1451 04 9	84	12
Cutter B	41.0	27.0	1452 04 9	84	12
<b>Cutter A</b>					
Profile Cutter	40.0	10.7	1450 24 0		
Groover	22.5	7.3	1450 12 0		
Groover	41.0	10.2	1431 06 0		
<b>Cutter B</b>					
Profile Cutter	38.0	11.6	1450 14 0		
Groover	41.0	6.3	1431 14 0		
Groover	22.0	11.0	1450 22 0		
			1910 13 0		

### Spare Parts:



Arbor & Nut  
#190 013 9  
L=84



Ball Bearing  
#191 013 0  
8x22x7



Washer  
#192 011 0  
1x16



Spacer  
#192 100 0  
0.1x16



Spacer  
#192 050 0  
0.05x16

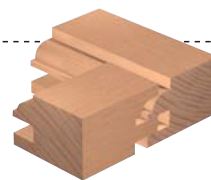

Drilling



Routing

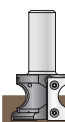

Custom Tooling



# Routing

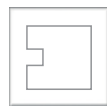

Grooving & Sizing

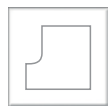

Profiling & Chamfering

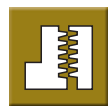

Jointing & Rebating



Carving



Corian



## Tongue & Groove Classic Set

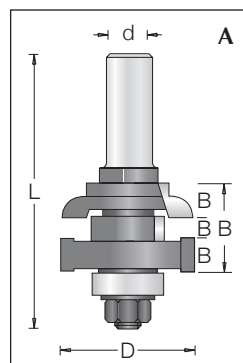

	øD	B	Code No.	L	ød
<b>Complete</b>			1450 03 9		
Cutter A	41.0	27.0	1451 03 9	84	12
Cutter B	41.0	27.0	1452 03 9	84	12
<b>Cutter A</b>					
Profile Cutter	40.0	10.7	1450 23 0		
Groover	22.5	7.3	1450 12 0		
Groover	41.0	10.2	1431 06 0		
<b>Cutter B</b>					
Profile Cutter	38.0	11.6	1450 13 0		
Groover	41.0	6.3	1431 14 0		
Groover	22.0	11.0	1450 22 0		

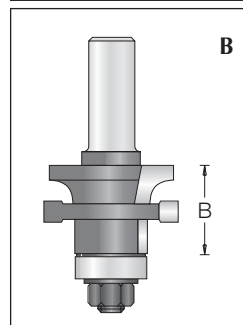
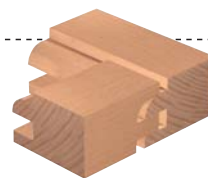

### Spare Parts:



Arbor & Nut  
#190 013 9  
L=84



Ball Bearing  
#191 013 0  
8x22x7



Washer  
#192 011 0  
0.1x16



Spacer  
#192 100 0  
0.1x16



Spacer  
#192 050 0  
0.05x16

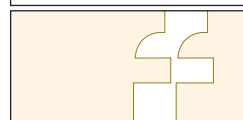

Sawing



CNC

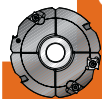

Cutting

## Tongue & Groove Classic Set

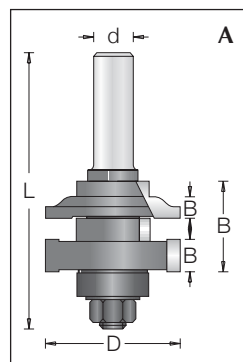

	øD	B	Code No.	L	ød
<b>Complete</b>			1450 02 9		
Cutter A	41.0	27.0	1451 02 9	84	12
Cutter B	41.0	27.0	1452 02 9	84	12
<b>Cutter A</b>					
Profile Cutter	41.0	10.9	1431 01 L		
Groover	22.0	7.3	1450 12 0		
Groover	41.0	10.2	1431 06 0		
<b>Cutter B</b>					
Profile Cutter	41.0	10.9	1431 31 0		
Groover	41.0	6.3	1431 14 0		
Groover	22.0	11.0	1450 22 0		

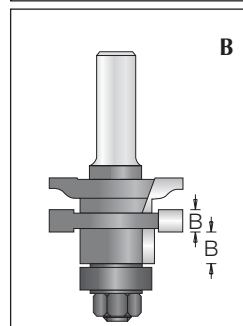
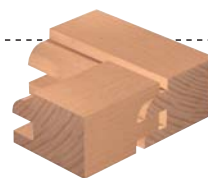

### Spare Parts:



Arbor & Nut  
#190 013 9  
L=84



Ball Bearing  
#191 013 0  
8x22x7



Washer  
#192 011 0  
0.1x16



Spacer  
#192 100 0  
0.1x16



Spacer  
#192 050 0  
0.05x16

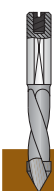
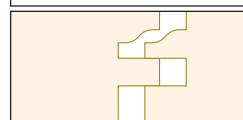

Drilling

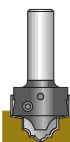

Routing

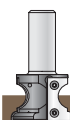

Custom Tooling