

# Drilling

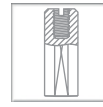

CNC & Automatic Machines

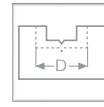

Multi Purpose Boring



Slot Mortising



Counter Sinking & Plug maker

## Dirose™ Profile for Rosettes.

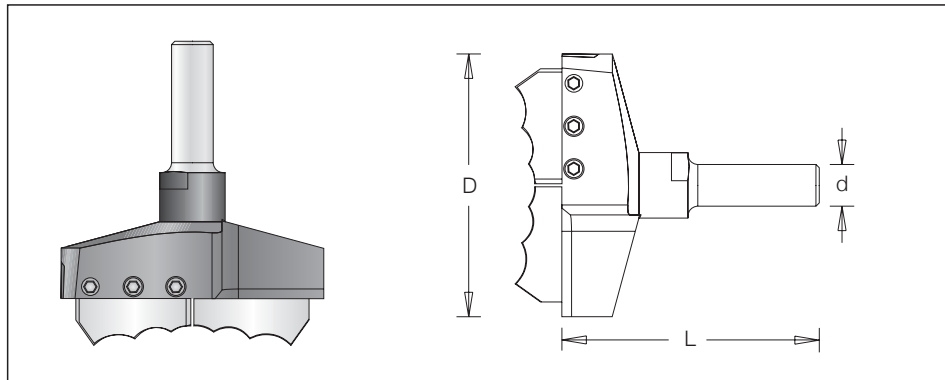

	øD	Code No.	L	ød	Profile
Dirose Set	79.6	180 100 9	81	12	5x2 - Profile knives as per your choice
Dirose	79.6	180 001 9	81	12	

⚠ Check that the speed is suitable for the type of wood being worked:  
 MDF: 3000-6000 RPM  
 Soft Wood: 3000-6000 RPM  
 Hard Wood: 1500-2000 RPM

## Dirose™ Cutter

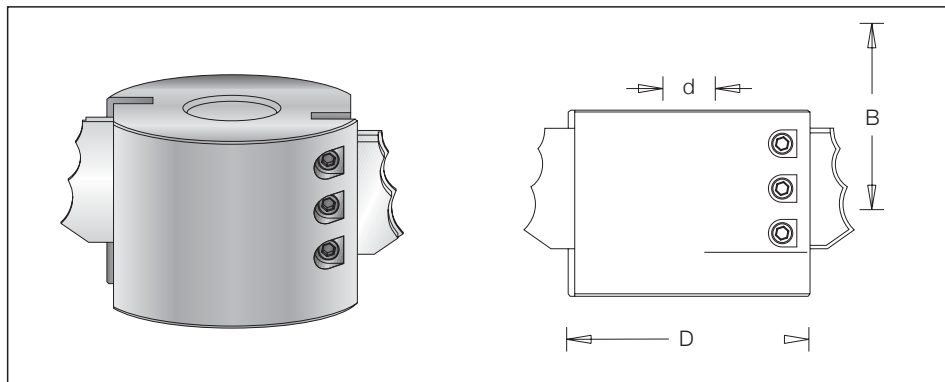

	øD	Code No.	B	ød	Profile
Dirose Cutter	74	180 002 1	54	30	
Dirose & Dirose Cutter Set		180 200 9			5x2 - Profile knives as per your choaie

⚠ Can be supplied with 5/8", 3/4" and 1".

### Spare Parts:



Allen screw  
#193 065 0



Allen key  
1940090

Index

Sawing

CNC

Cutting

Drilling

Routing

Custom Tooling



# Drilling

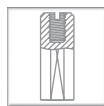

CNC & Automatic Machines

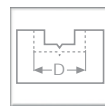

Multi Purpose Boring



Slot Mortising



Counter Sinking & Plug maker



## Dirose™ Profile Shapes Available

1800010 *		1800090	
1800010		1800100	
1800020 *		1800100 *	
1800020		1800110	
1800030		1800120	
1800040		1800120 *	
1800050		1800130	
1800060		1800130 *	
1800070		1800140	
1800080		1800150	



\* With this knife it is possible to execute both a depressed rosette in the wood and a protruding rosette (button) for gluing.



Sawing



CNC

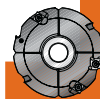

Cutting



Drilling



Routing

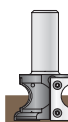

Custom Tooling