

Drilling

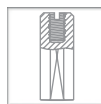

CNC & Automatic Machines

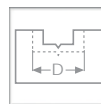

Multi Purpose Boring

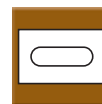

Slot Mortising

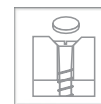

Counter Sinking & Plug maker

3 Steps Drill Bits

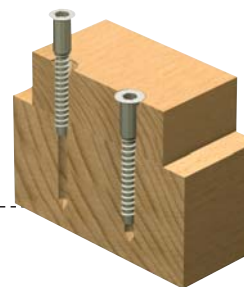
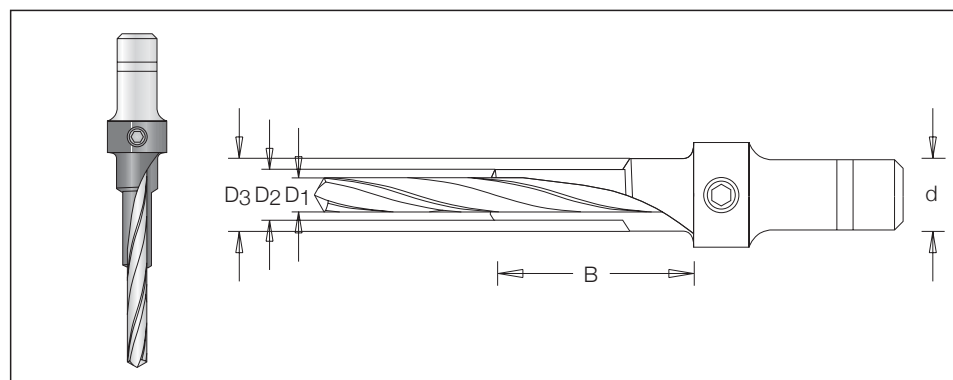

$\phi D1$	$\phi D2$	$\phi D3$	Code No.	B	L	ϕd
3.5	5	7	202 605 7	30	60	10
5.0	7	10	202 610 7	30	60	10

! For Connecting screws.
2 steps steel made countersink, surface treated for very high hardness.
 α HSS Slow spiral drill.

2021 - Countersink H.S.S. Drill

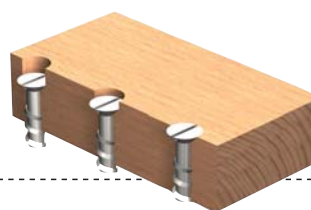
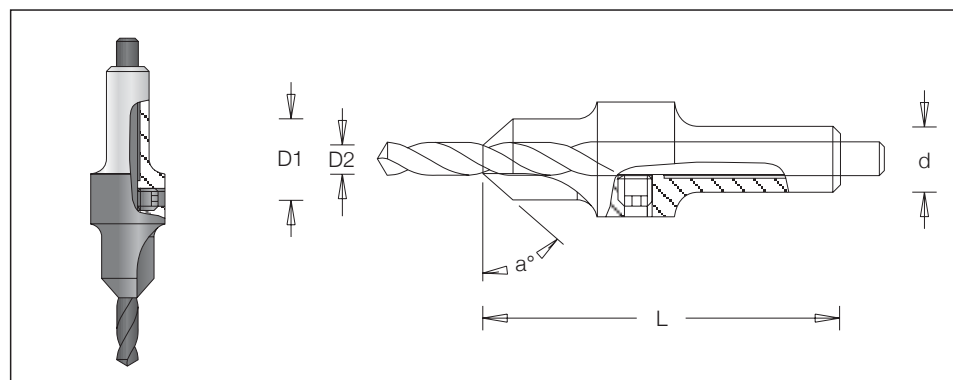

$\phi D1$	$\phi D2$	a	Code No.	L	ϕd
8.0	2.4	41°	2021 25 0	43	8.0
8.0	3.2	41°	2021 28 0	43	8.0
9.5	3.2	41°	2021 30 0	43	8.0
12.7	3.2	41°	2021 33 0	43	8.0
10.0	3.6	41°	2021 35 0	43	8.0
10.0	4.0	41°	2021 40 0	43	8.0
10.0	4.4	41°	2021 45 0	43	8.0
11.1	4.8	41°	2021 50 0	47	9.5
12.7	4.8	41°	2021 55 0	47	9.5
12.0	5.6	41°	2021 57 0	47	9.5
12.7	5.6	41°	2021 53 0	47	9.5
12.7	6.0	41°	2021 60 0	47	9.5
12.7	6.3	41°	2021 65 0	47	10.0
13.5	6.3	41°	2021 63 0	47	10.0

Index

Sawing

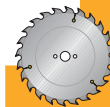

CNC

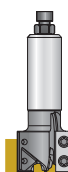

Cutting

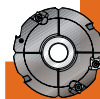

Drilling



Routing



Custom Tooling

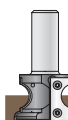

Drilling

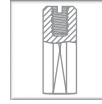

CNC &
Automatic
Machines

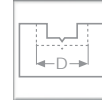

Multi
Purpose
Boring



Slot
Mortising



Counter
Sinking &
Plug maker

Countersink & H.S.S. Drill

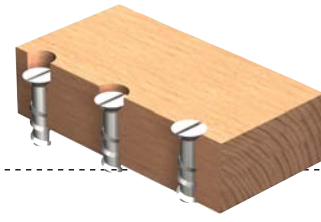
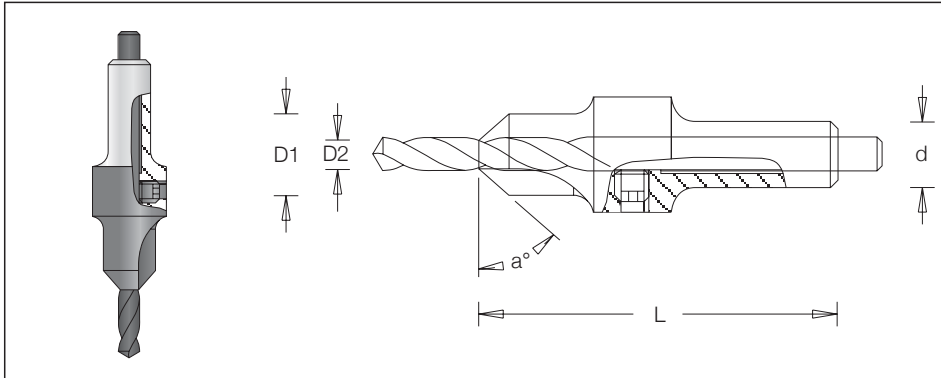

$\varnothing D1$	$\varnothing D2$	a	Code No.	L	$\varnothing d$
10	3.0	45°	2022 30 5	48	8
10	3.2	41°	2022 32 5	48	8
10	3.5	45°	2022 35 5	48	8
10	3.6	41°	2022 36 5	48	8
10	4.0	45°	2022 40 5	48	8
10	4.4	41°	2022 45 5	48	8
10	5.0	45°	2022 50 5	48	8

Plug Maker

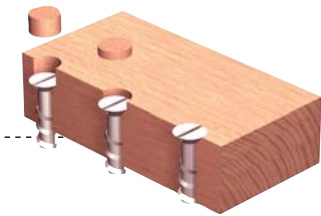
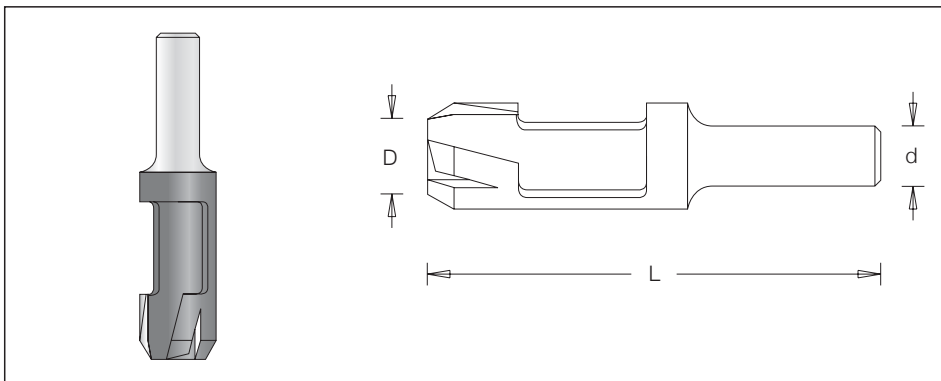

$\varnothing D$	Code No.	L	$\varnothing d$
10.0	2034 01 7	60	8
12.7	2034 02 7	60	10
16.0	2034 03 7	76	10
19.0	2034 04 7	76	10

SET Countersink & Plug Maker

$\varnothing D$	Code No.
3.5	202 335 5
4.0	202 340 5
5.0	202 350 5

! Set includes countersinks and plug maker with which it is possible to produce wooden caps from the same wood being worked, in order to conceal the screw.