

# Drilling

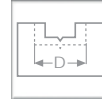

CNC & Automatic Machines



Multi Purpose Boring



Slot Mortising



Counter Sinking & Plug maker

## 203 T - Combi Chuck

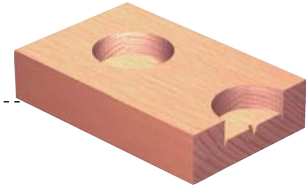
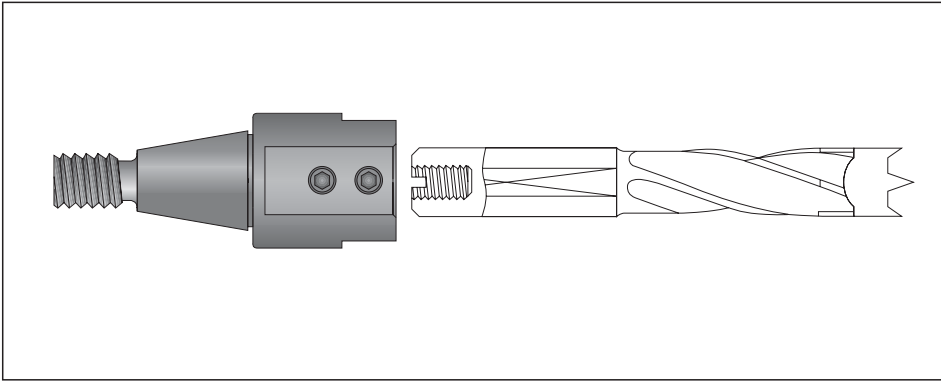

| For Machines                                  | øD | Code No.  |           | M  | L1 | L  | ød |
|---|----|-----------|-----------|----|----|----|----|
|   |    | Right     | Left      |    |    |    |    |
| Nottmeyer                                     | 20 | 203 901 5 | 203 904 5 | 8  | 15 | 40 | 10 |
|   | 20 | 203 906 5 | 203 907 5 | 8  | 16 | 41 | 10 |
|   | 20 | 203 909 5 | 203 911 5 | 8  | 15 | 52 | 10 |
| Vitap, Busselato, Ompex                       | 20 | 203 920 7 | 203 923 7 | 10 | 12 | 47 | 10 |
| Bilek   | 20 | 203 925 5 | 203 927 5 | 8  | 12 | 51 | 10 |
| Ayen, Torwegge, Holzma                        | 20 | 203 940 7 | 203 943 7 | 10 | 15 | 40 | 10 |
| Holzma, S.C.M.I., Morbidelli, Bisse, Torwegge | 20 | 203 930 7 | 203 933 7 | 10 | 16 | 41 | 10 |
| Scheer  | 20 | 203 960 7 | 203 963 7 | 10 |    | 46 | 10 |

**⚠** Advanced chuck system replacing thread-shank tools. Suitable for most automatic multi-spindle drilling machines.

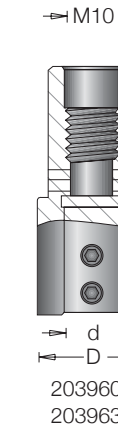
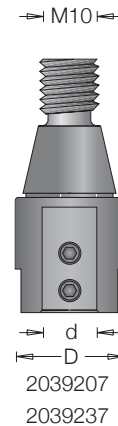
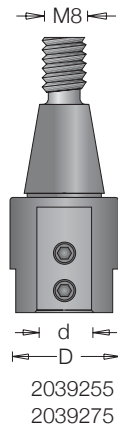
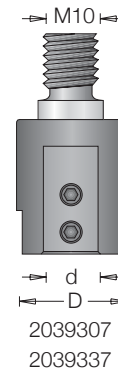
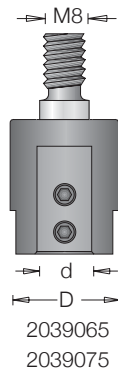
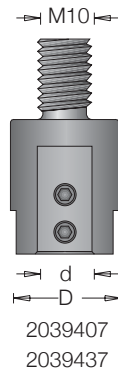
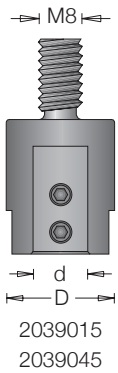

Index

Sawing

CNC

Cutting

Drilling

Routing

Custom Tooling

# Drilling



CNC &  
Automatic  
Machines

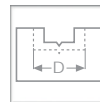

Multi  
Purpose  
Boring



Slot  
Mortising

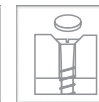

Counter  
Sinking &  
Plug maker

## 2039 - HSS Drills with HM hed

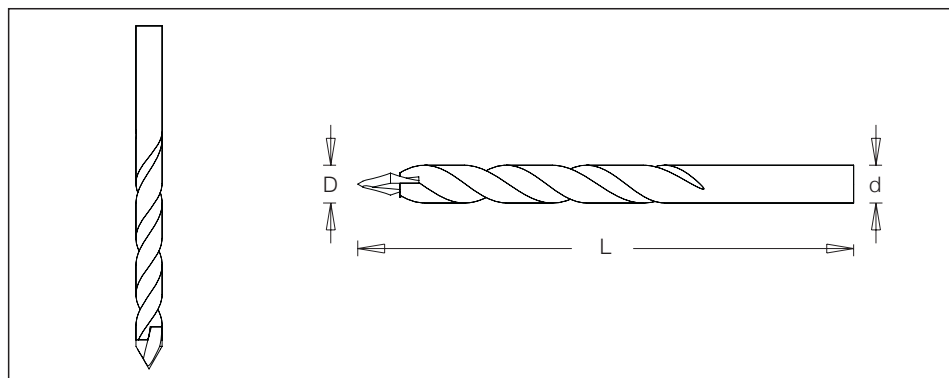

| øD1  | Code No.  | L   | ød   |
|------|-----------|-----|------|
| 4.0  | 205 104 0 | 74  | 4.0  |
| 5.0  | 205 110 0 | 85  | 5.0  |
| 6.0  | 205 114 0 | 92  | 6.0  |
| 7.0  | 205 118 0 | 89  | 7.0  |
| 8.0  | 205 122 0 | 116 | 8.0  |
| 9.0  | 205 128 0 | 126 | 9.0  |
| 10.0 | 205 132 0 | 134 | 10.0 |
| 11.0 | 205 134 0 | 147 | 11.0 |
| 12.0 | 205 138 0 | 150 | 12.0 |

## 2039 - Chuck Adapter for Solid HM Or HS Drills

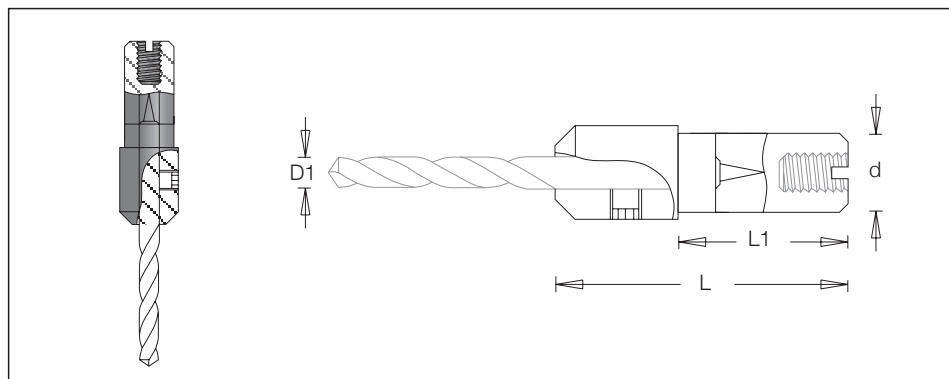

| øD1 | Code No.  | L1 | L  | ød |
|-----|-----------|----|----|----|
| 2.0 | 203 950 7 | 22 | 38 | 10 |
| 2.5 | 203 951 7 | 22 | 38 | 10 |
| 3.0 | 203 952 7 | 22 | 38 | 10 |
| 3.2 | 203 953 7 | 22 | 38 | 10 |
| 3.5 | 203 954 7 | 22 | 38 | 10 |
| 4.0 | 203 955 7 | 22 | 38 | 10 |
| 5.0 | 203 956 7 | 22 | 38 | 10 |



Screw  
#193 000 0  
M5x10

Index

Sawing

CNC

Cutting

Drilling

Routing

Custom Tooling