

# Drilling

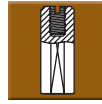

CNC &  
Automatic  
Machines

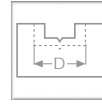

Multi  
Purpose  
Boring



Slot  
Mortising



Counter  
Sinking &  
Plug maker

Index

## 201 Bk - Through Hole Drilling

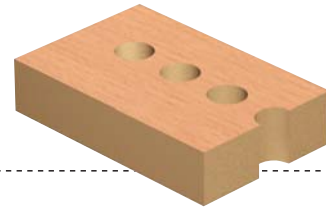
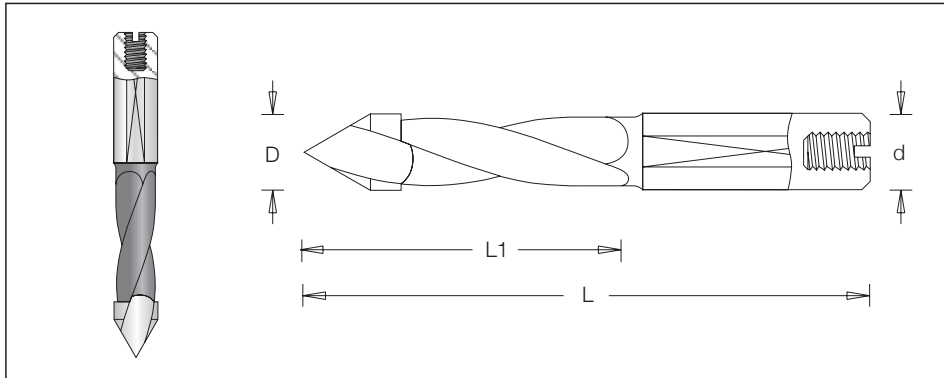

Sawing



øD	Code No.		L1	L	ød
	Right	Left			
4	201 600 7	201 601 7	25	57.5	10x25
5	201 604 7	201 605 7	25	57.5	10x25
6	201 606 7	201 607 7	25	57.5	10x25
7	201 650 7	201 651 7	25	57.5	10x25
8	201 608 7	201 609 7	25	57.5	10x25
9	201 656 7	201 657 7	25	57.5	10x25
10	201 612 7	201 613 7	25	57.5	10x25



Screw  
#193 000 0  
M5x10

CNC



## 201 Bk - Through Hole Drilling

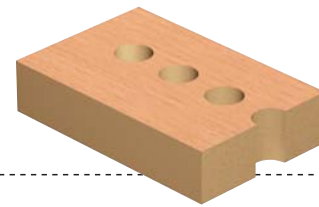
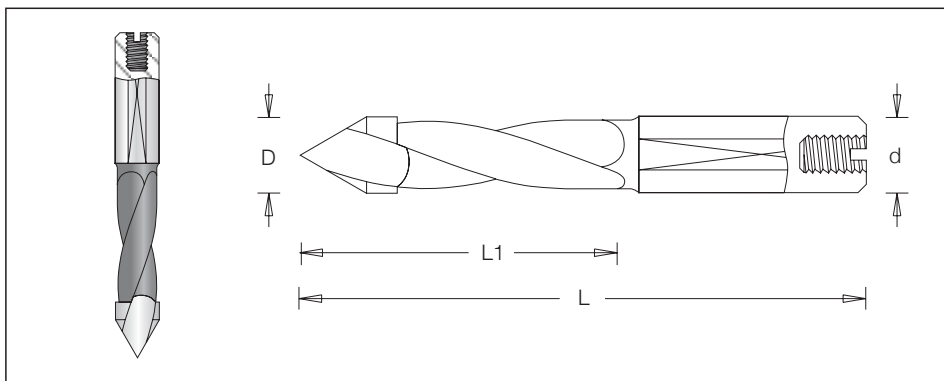

Cutting

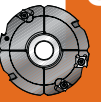

øD	Code No.		L1	L	ød
	Right	Left			
5	201 614 7	201 615 7	40	70	10x25
6	201 616 7	201 617 7	40	70	10x25
7	201 661 7	201 662 7	40	70	10x25
8	201 618 7	201 619 7	40	70	10x25
9	201 667 7	201 668 7	40	70	10x25
10	201 622 7	201 623 7	40	70	10x25
12	201 686 7	201 687 7	40	70	10x25



Screw  
#193 000 0  
M4x10

Drilling

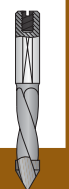

Routing



Custom Tooling

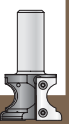

# Drilling



CNC &  
Automatic  
Machines

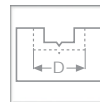

Multi  
Purpose  
Boring



Slot  
Mortising

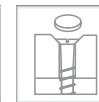

Counter  
Sinking &  
Plug maker

## 201 Bk - Through Hole Drilling

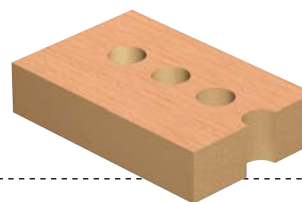
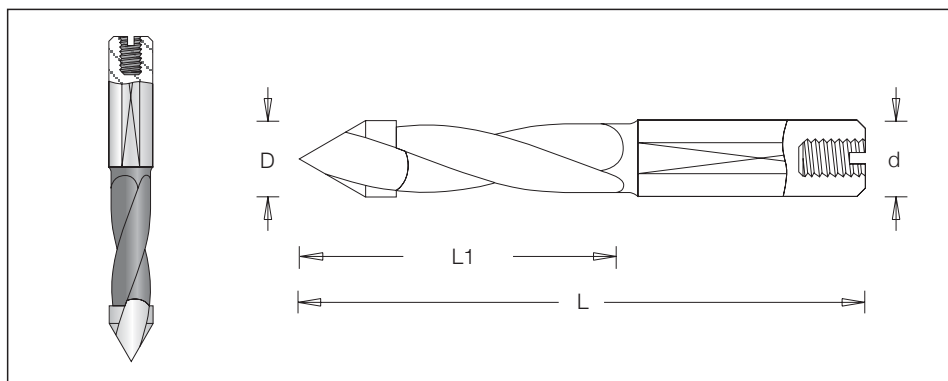

øD	Code No.		L1	L	ød
	Right	Left			
5	201 624 7	201 625 7	45	77	10x25
6	201 626 7	201 627 7	45	77	10x25
7	201 631 7	201 632 7	45	77	10x25
8	201 628 7	201 629 7	45	77	10x25
9	201 637 7	201 638 7	45	77	10x25
10	201 641 7	201 642 7	45	77	10x25



Screw  
#193 000 0  
M5x10

## 201 Bk - Through Hole Drilling 8mm Shank

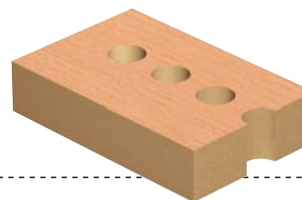
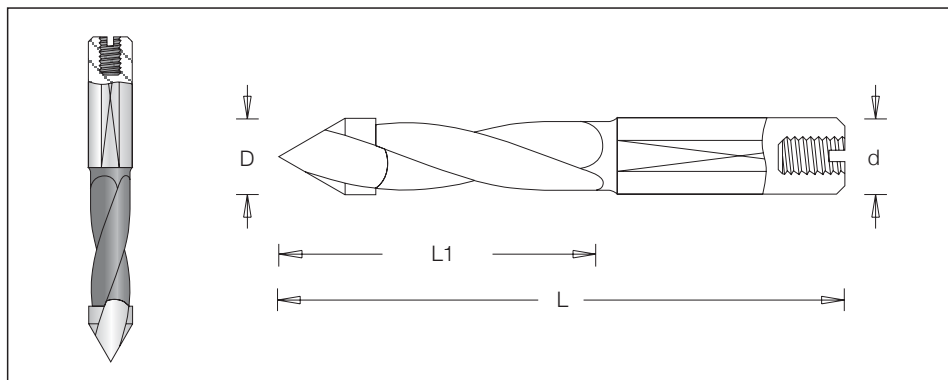

øD	Code No.		L1	L	ød
	Right	Left			
5	201 604 5	201 605 5	25	55.5	8x20
8	201 608 5	201 609 5	25	55.5	8x20
5	201 614 5	201 615 5	35	67.0	8x20
8	201 618 5	201 619 5	35	67.0	8x20



Screw  
#193 000 0  
M5x10

Index

Sawing

CNC

Cutting

Drilling

Routing

Custom Tooling