

Cutting



Grooving Rebating Planing Profiling Jointing Frame & Panel door **Lamello** Multi Profile system

Multi Profile System Cutter

Cutterhead bodies in hard wearing aluminium or steel complete with two tool steel rebate knives and corresponding limiter plates. Suitable for jointing, rebating and profiling with 4mm thick knives and limiters in softwood and hardwood. 114mm diameter cutterhead for use with the 50 x 4mm knives and limiters on pages 96 - 101.

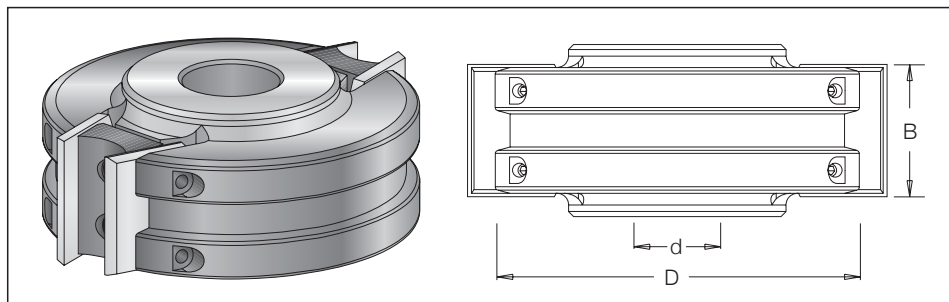

$\varnothing D$	B	Code No.	Teeth	$\varnothing d$	n
93	40	776 006 1	2	30	6,000 - 9,000
100	40	776 105 1 *	2	30	5,000 - 8,000
114	40/50	776 008 1	2	30	5,000 - 8,000
120	40	776 107 1 *	2	30	5,100 - 7,900

* Aluminum

Spare parts:

Knife	Limiter	Wedge	Allen screw	Allen key
#331 914 0	#341 914 0	#199 801 0	#193 026 6	#194 003 6
40x20x4	38x19x4	L = 38	M8x12	S4

Index

Sawing

CNC

Cutting

Drilling

Routing

Custom Tooling

Cutting

Multi Profile System 40 mm T.C.T

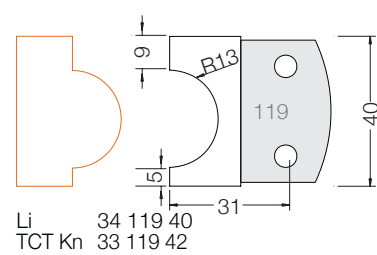
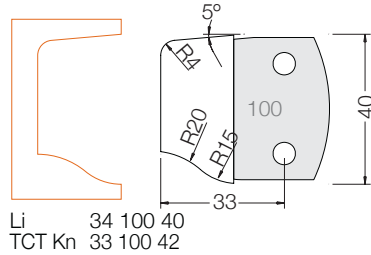
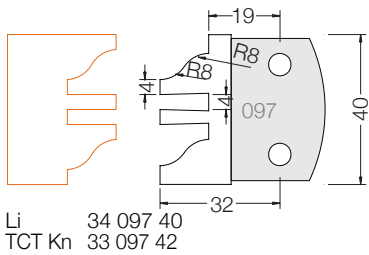
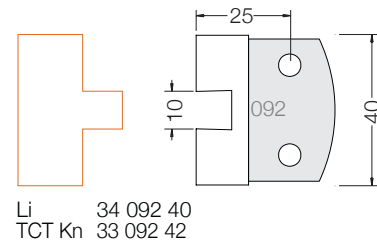
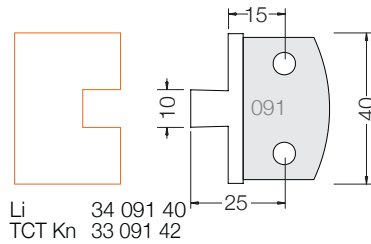
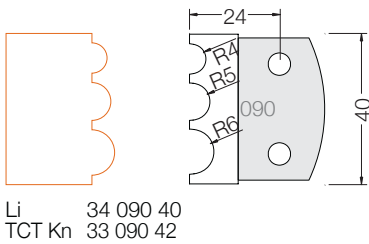
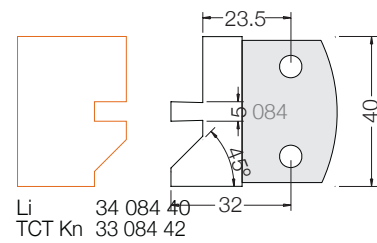
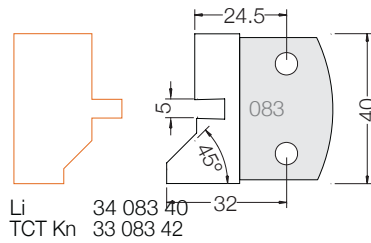
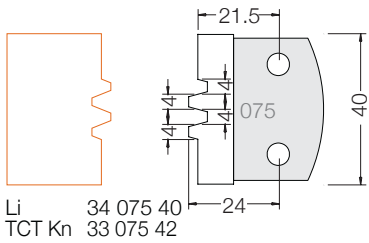
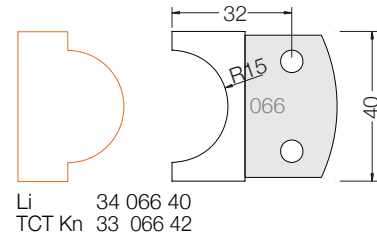
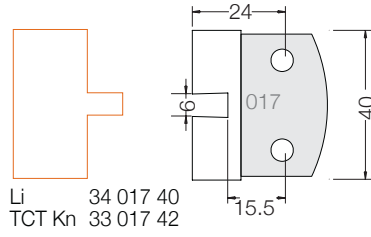
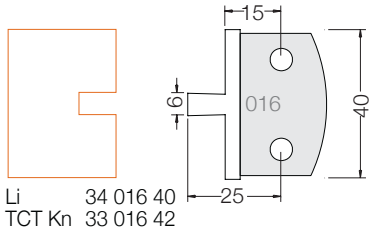

Sawing



CNC

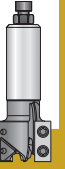

Cutting

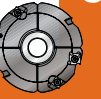

Drilling

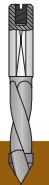

Routing



Custom Tooling

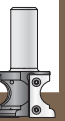

Cutting

Multi Profile System - 40mm

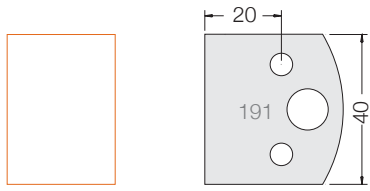

Kn 33 191 40
Li 34 191 40

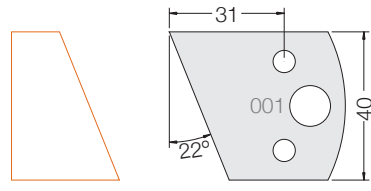

Kn 33 001 40
Li 34 001 40

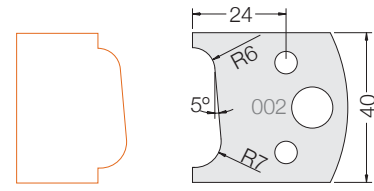

Kn 33 002 40
Li 34 002 40

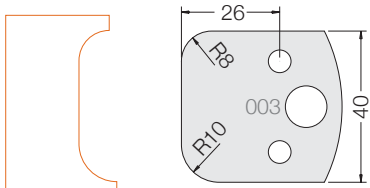

Kn 33 003 40
Li 34 003 40

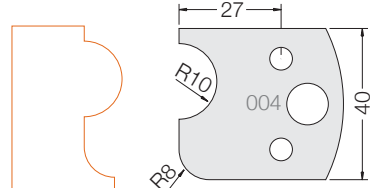

Kn 33 004 40
Li 34 004 40

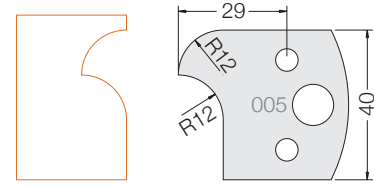

Kn 33 005 40
Li 34 005 40

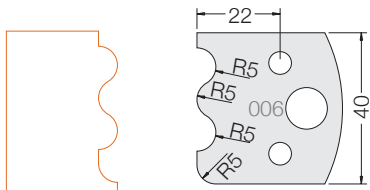

Kn 33 006 40
Li 34 006 40

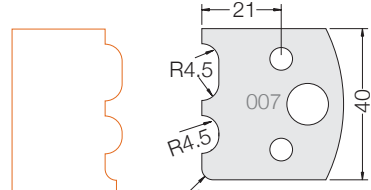

Kn 33 007 40
Li 34 007 40

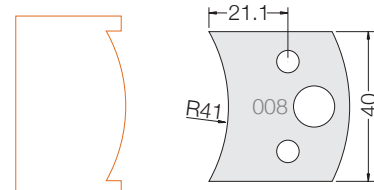

Kn 33 008 40
Li 34 008 40

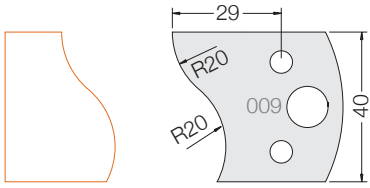

Kn 33 009 40
Li 34 009 40

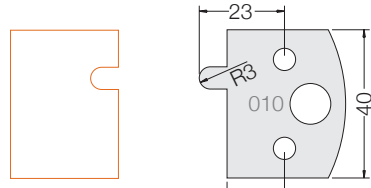

Kn 33 010 40
Li 34 010 40

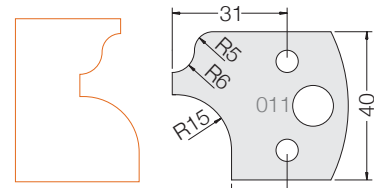

Kn 33 011 40
Li 34 011 40

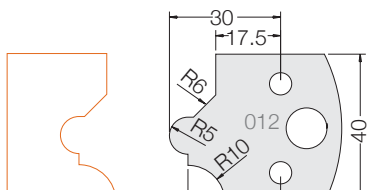

Kn 33 012 40
Li 34 012 40

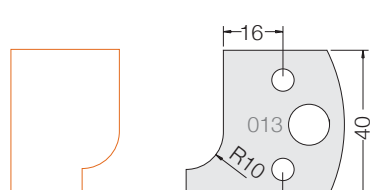

Kn 33 013 40
Li 34 013 40

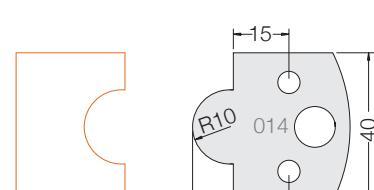

Kn 33 014 40
Li 34 014 40

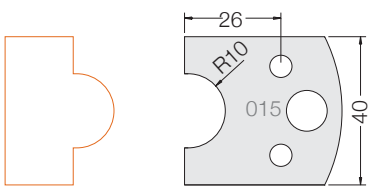

Kn 33 015 40
Li 34 015 40

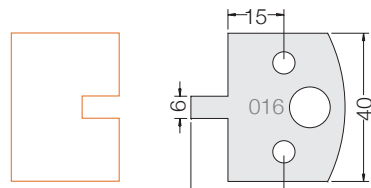

Kn 33 016 40
Li 34 016 40

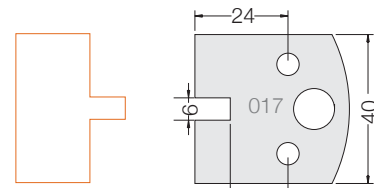

Kn 33 017 40
Li 34 017 40



Cutting

Multi Profile System - 40mm

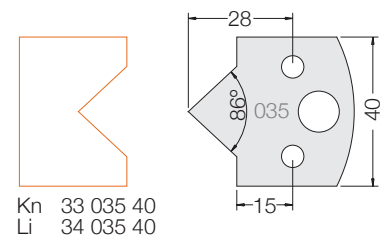
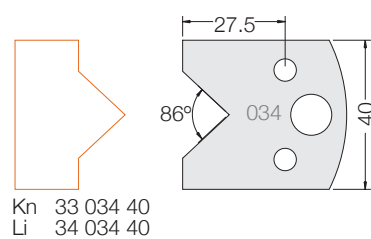
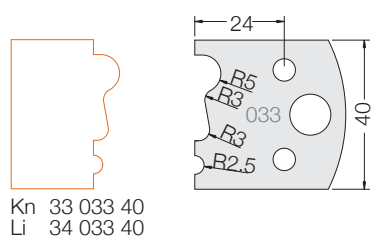
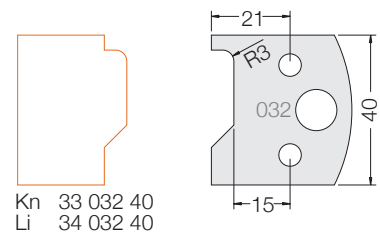
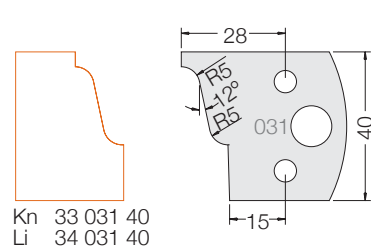
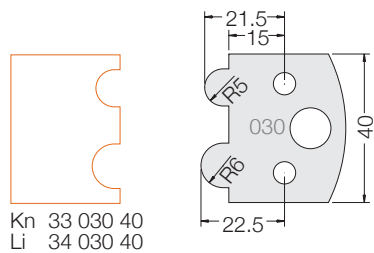
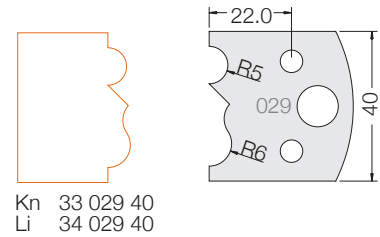
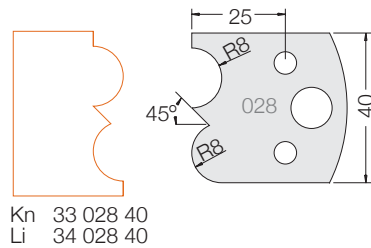
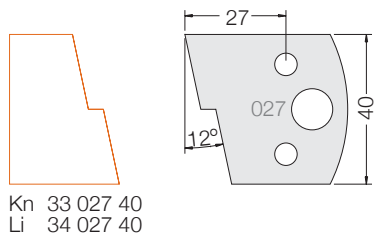
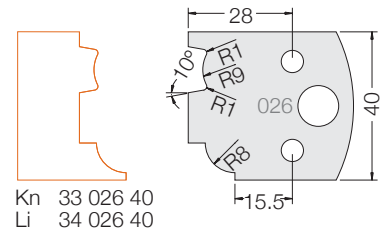
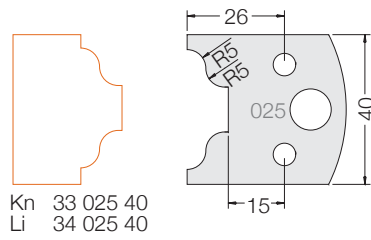
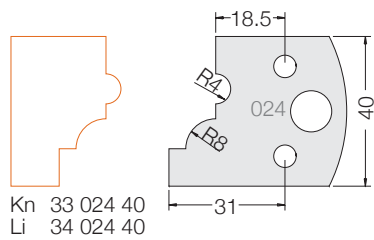
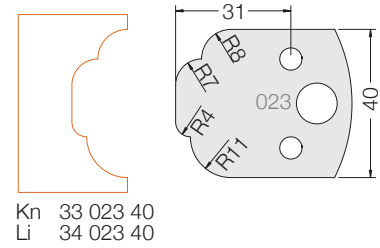
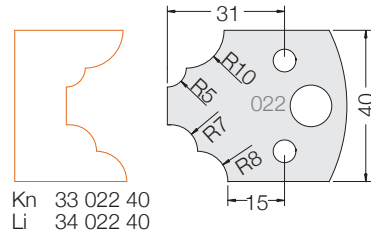
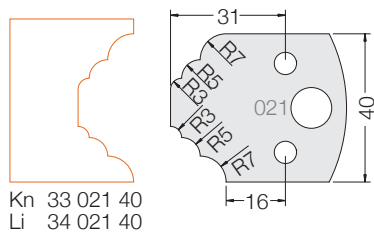
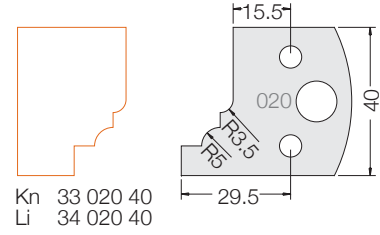
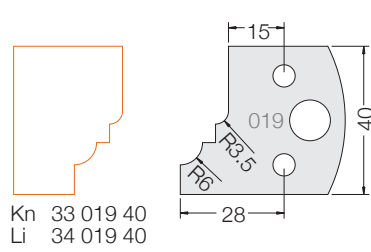
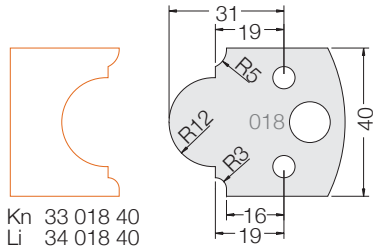

Sawing

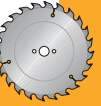

CNC

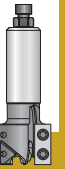

Cutting

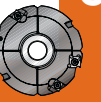

Drilling

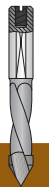

Routing



Custom Tooling

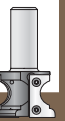

Cutting

Multi Profile System - 40mm

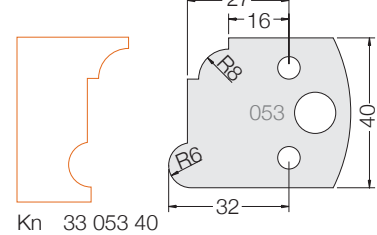
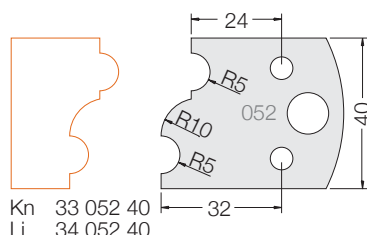
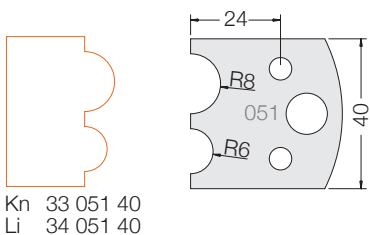
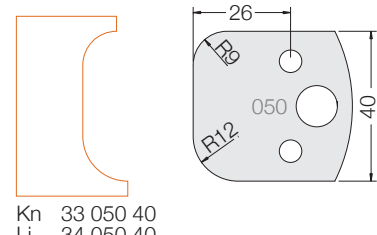
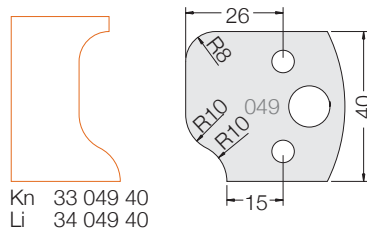
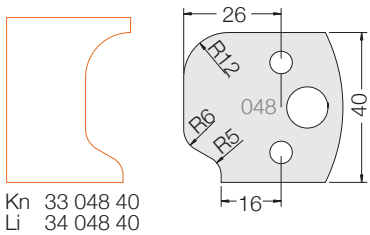
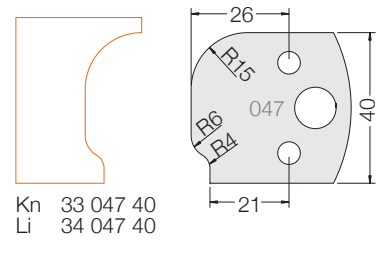
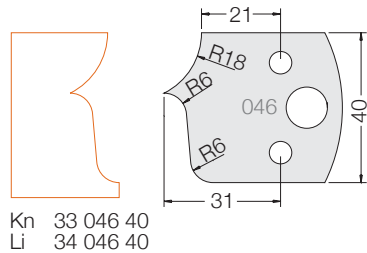
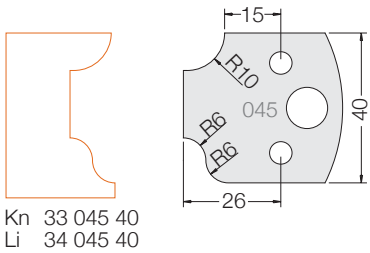
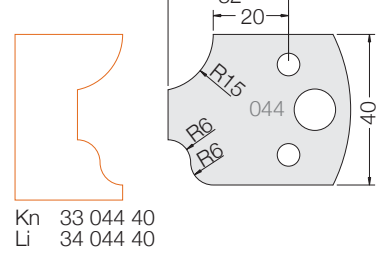
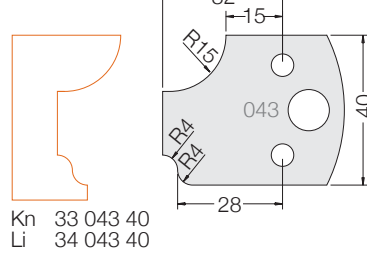
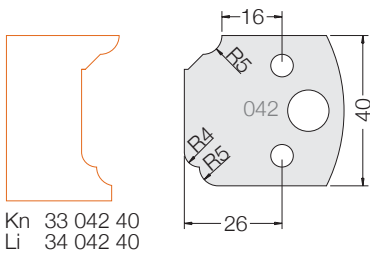
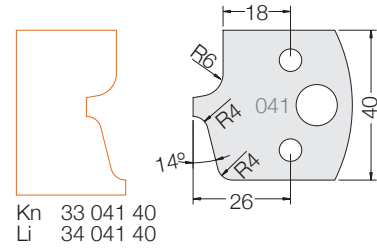
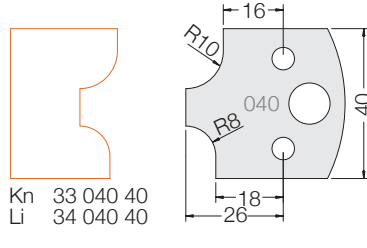
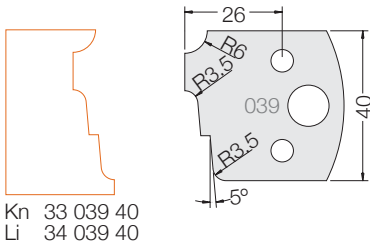
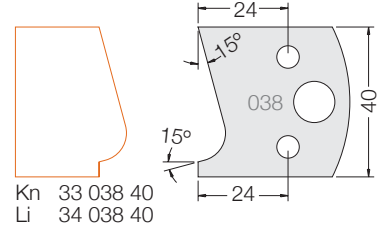
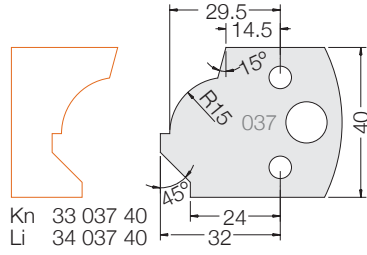
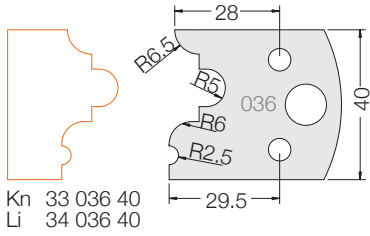

Index

Sawing

CNC

Cutting

Drilling

Routing

Custom Tooling



Cutting

Multi Profile System - 40mm

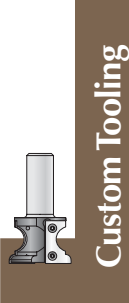
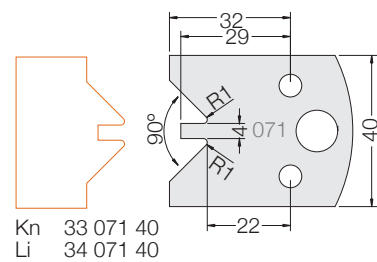
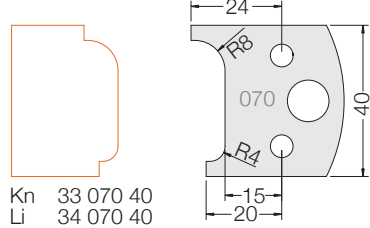
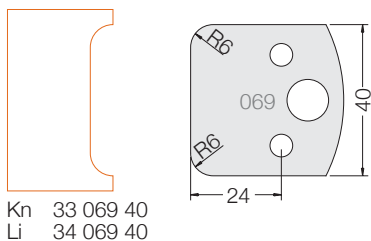
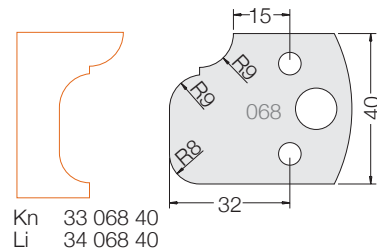
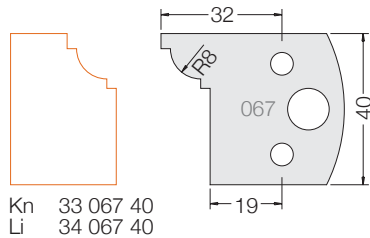
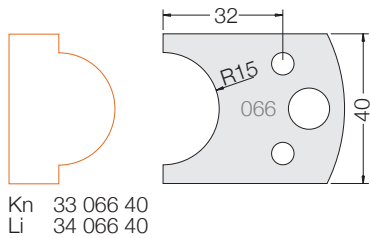
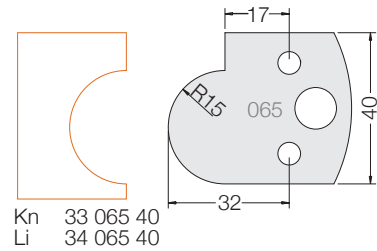
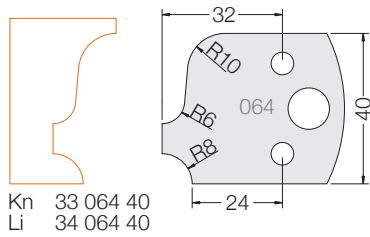
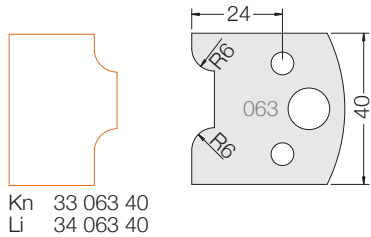
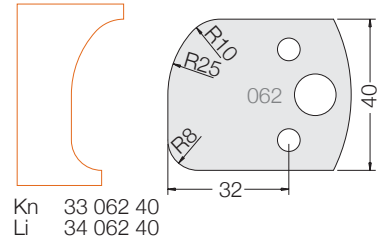
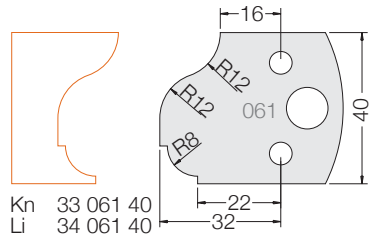
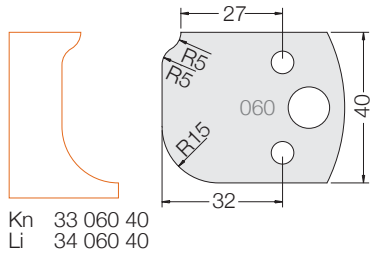
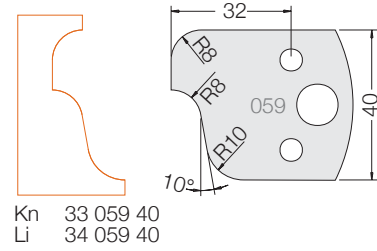
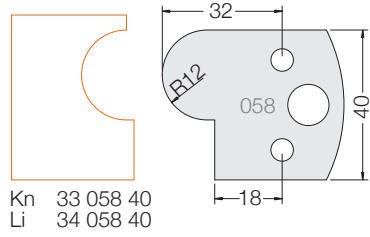
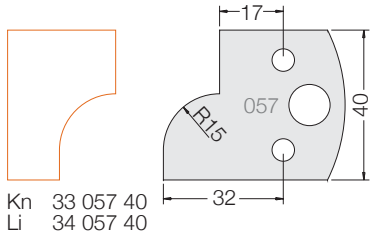
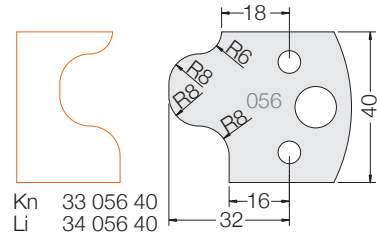
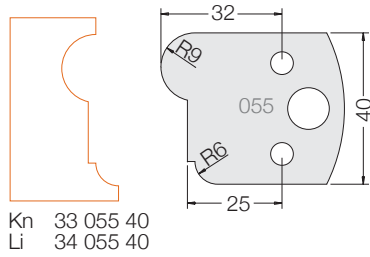
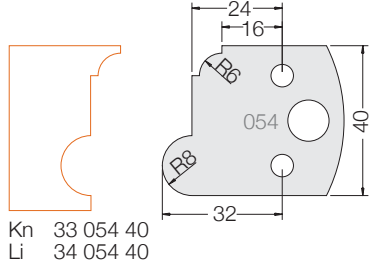

Cutting

Multi Profile System - 40mm

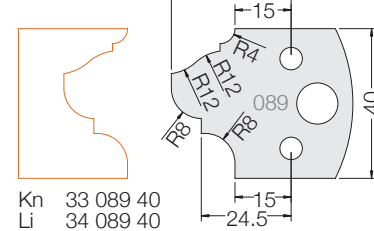
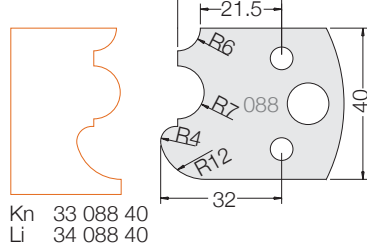
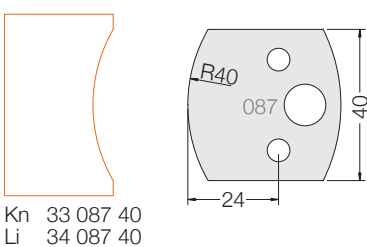
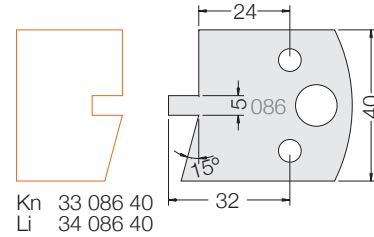
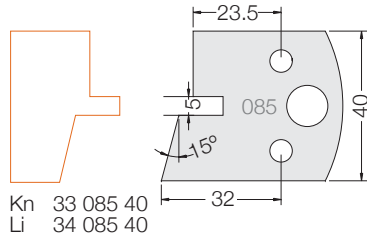
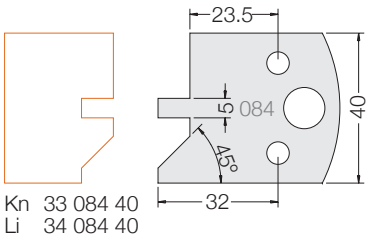
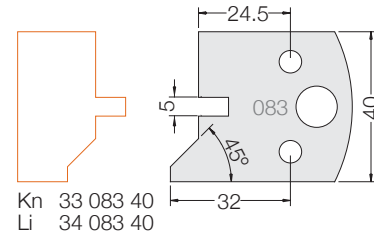
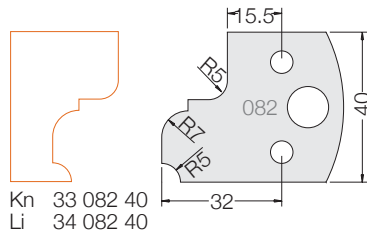
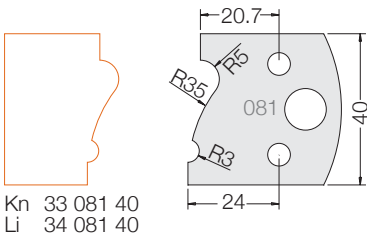
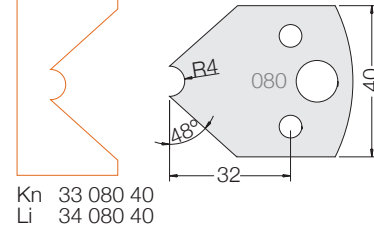
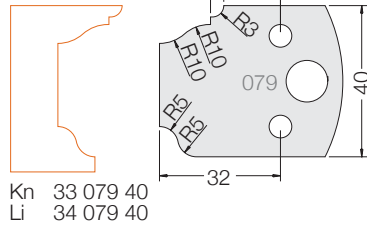
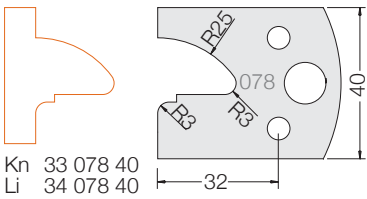
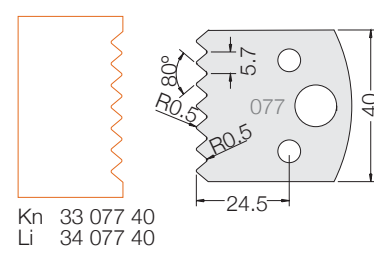
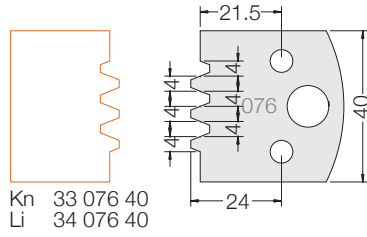
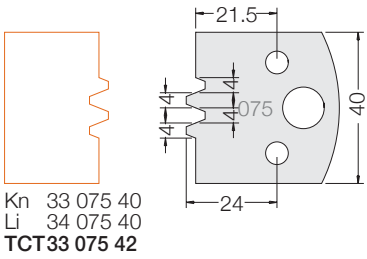
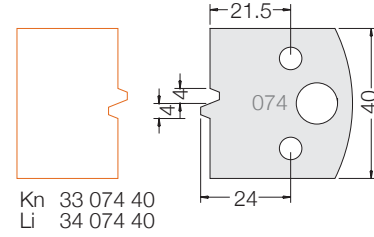
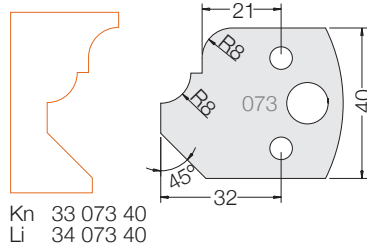
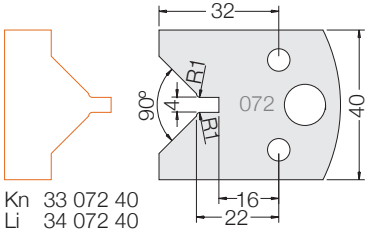

Cutting

Multi Profile System - 40mm

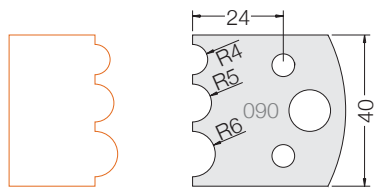

Kn 33 090 40
Li 34 090 40
TCT 33 090 42

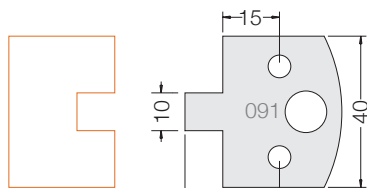

Kn 33 091 40
Li 34 091 40
TCT 33 091 42

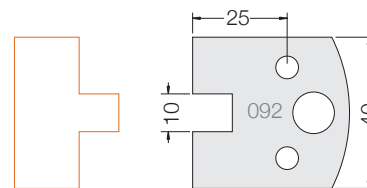

Kn 33 092 40
Li 34 092 40
TCT 33 092 42

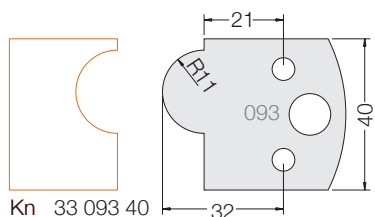

Kn 33 093 40
Li 34 093 40

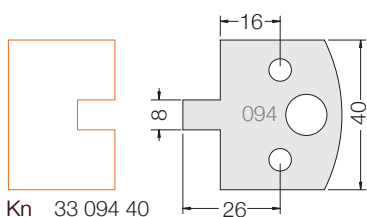

Kn 33 094 40
Li 34 094 40

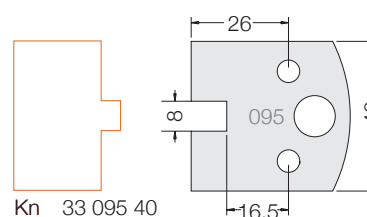

Kn 33 095 40
Li 34 095 40

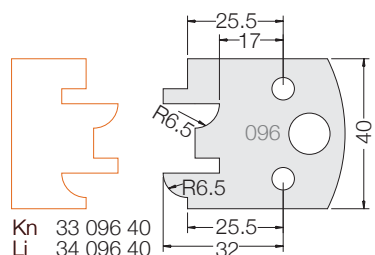

Kn 33 096 40
Li 34 096 40

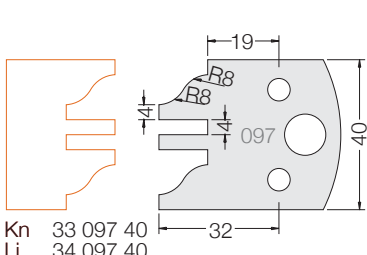

Kn 33 097 40
Li 34 097 40
TCT 33 097 42

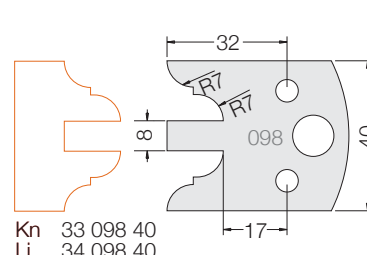

Kn 33 098 40
Li 34 098 40

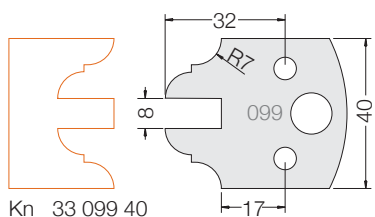

Kn 33 099 40
Li 34 099 40

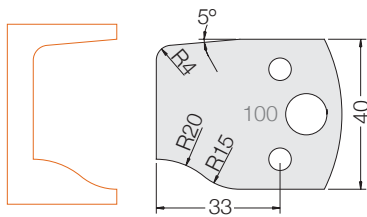

Kn 33 100 40
Li 34 100 40
TCT 33 100 42

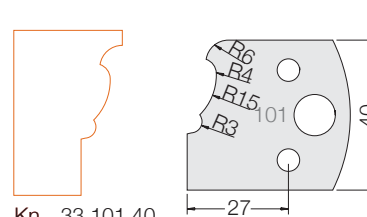

Kn 33 101 40
Li 34 101 40

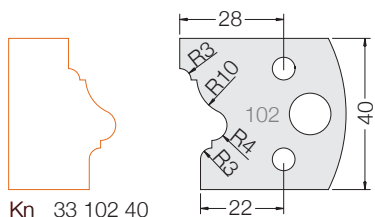

Kn 33 102 40
Li 34 102 40

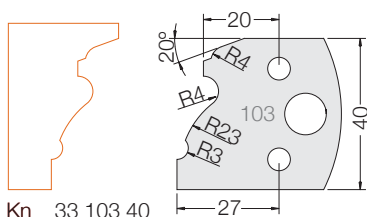

Kn 33 103 40
Li 34 103 40

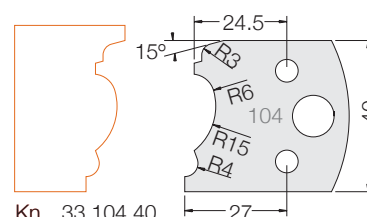

Kn 33 104 40
Li 34 104 40

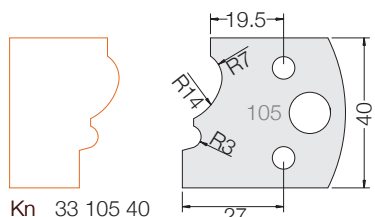

Kn 33 105 40
Li 34 105 40

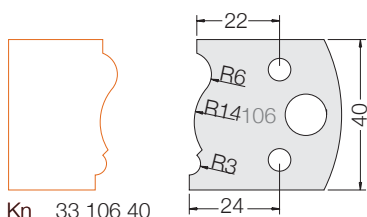

Kn 33 106 40
Li 34 106 40

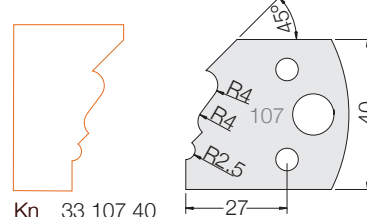

Kn 33 107 40
Li 34 107 40

Cutting

Multi Profile System - 40mm

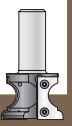
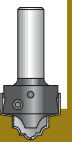
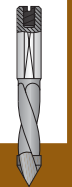
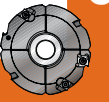
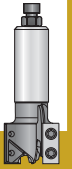
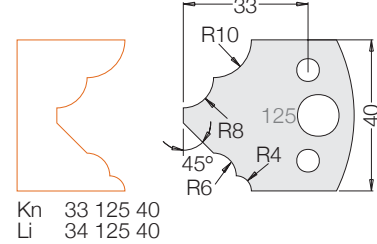
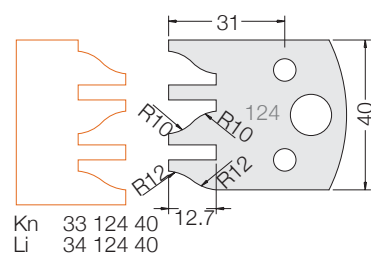
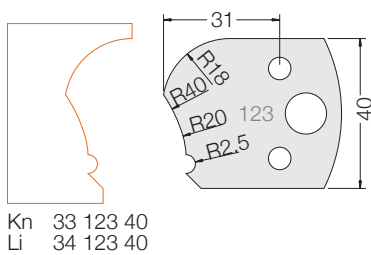
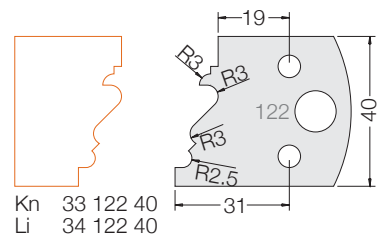
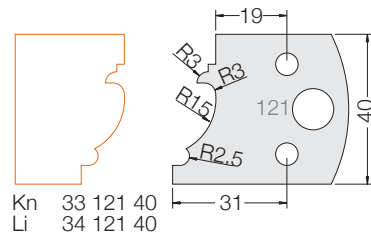
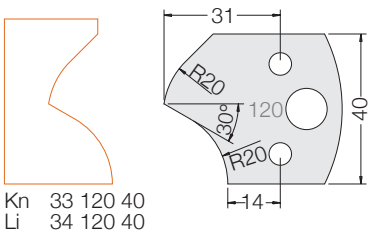
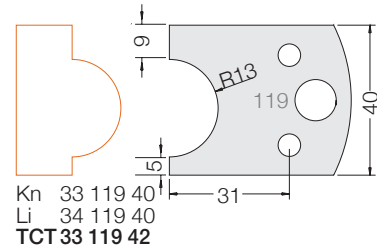
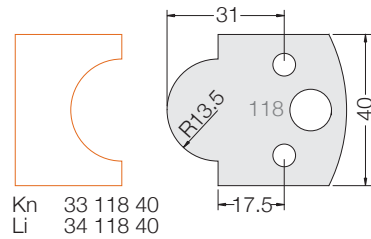
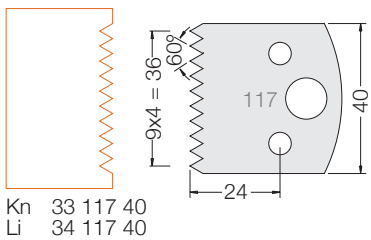
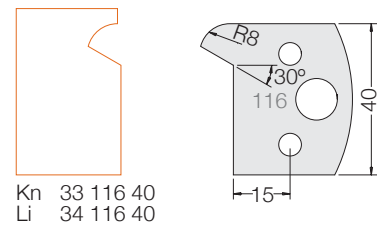
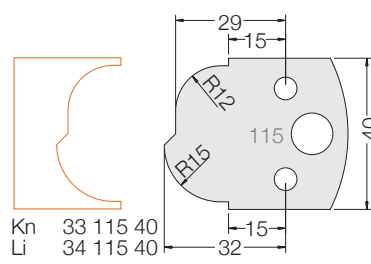
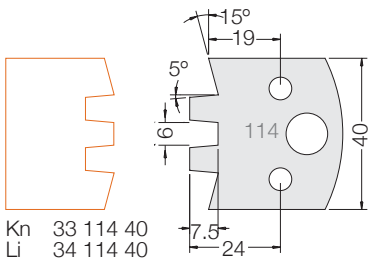
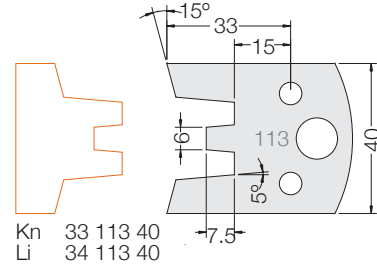
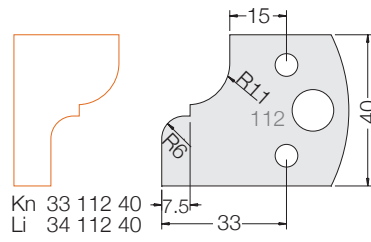
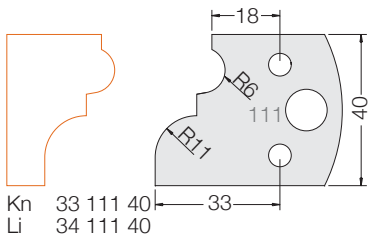
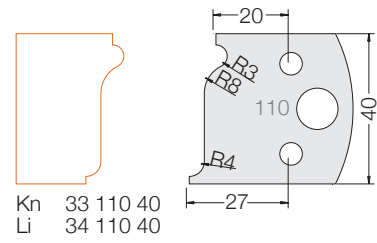
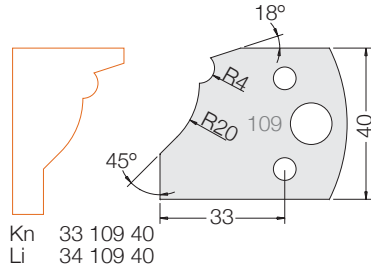
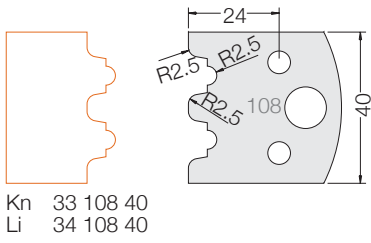

Cutting

Multi Profile System - 40mm

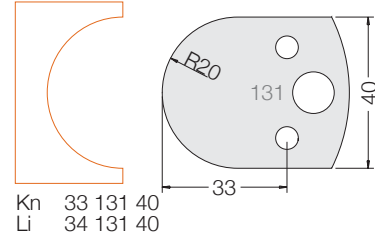
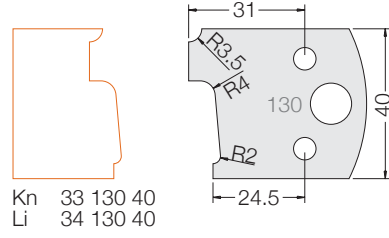
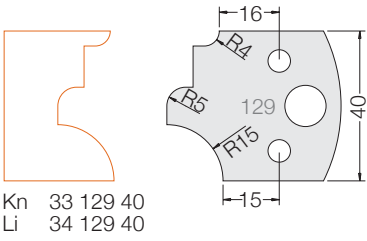
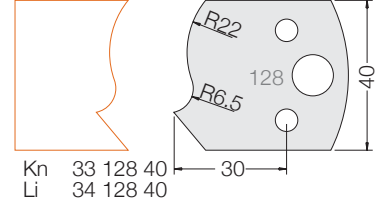
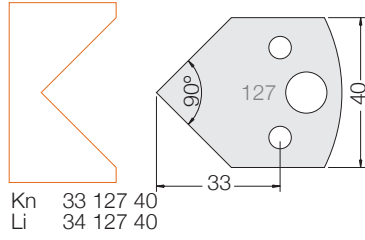
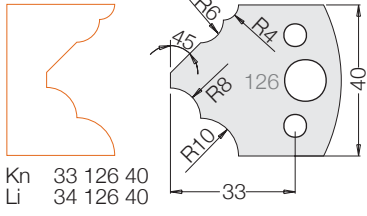

Index

Sawing

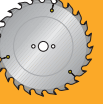

CNC

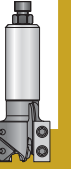

Cutting

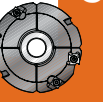

Drilling

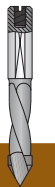

Routing

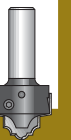

Custom Tooling

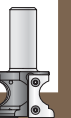

Cutting

Multi Profile System - 50mm

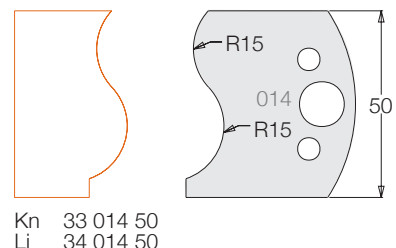
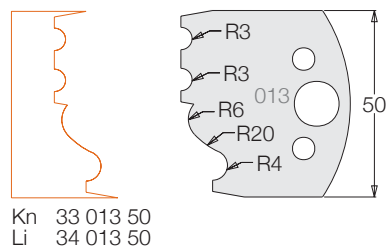
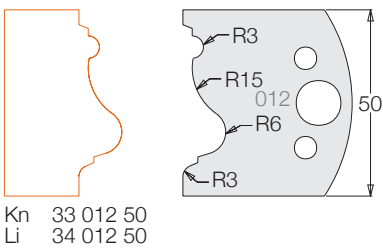
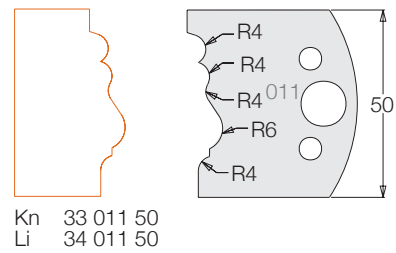
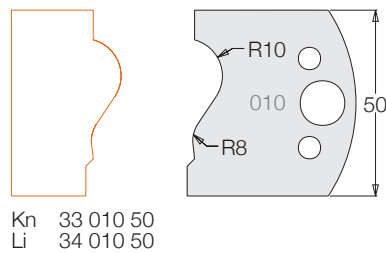
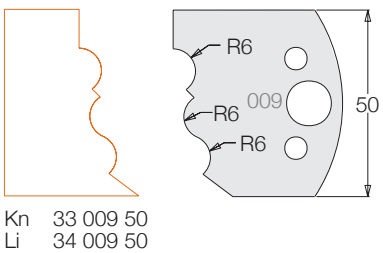
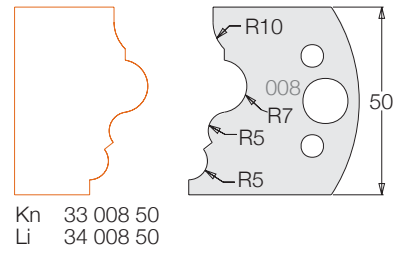
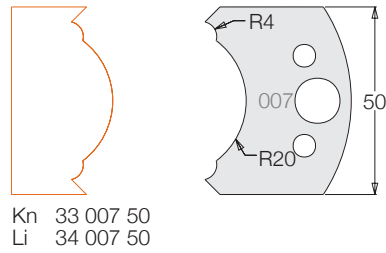
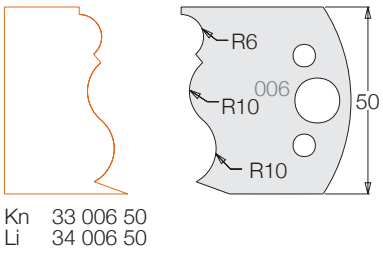
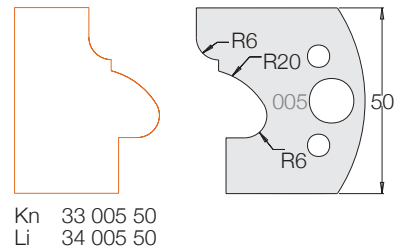
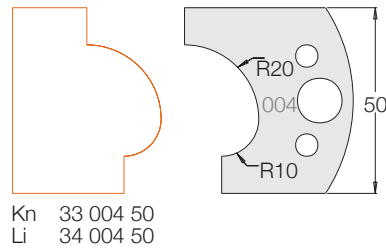
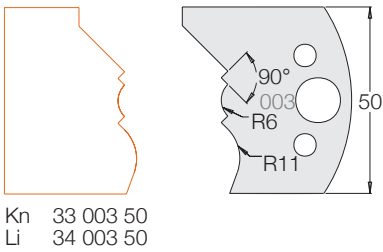
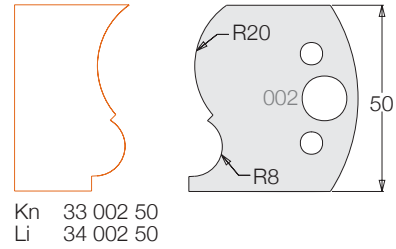
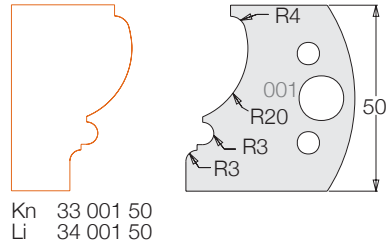
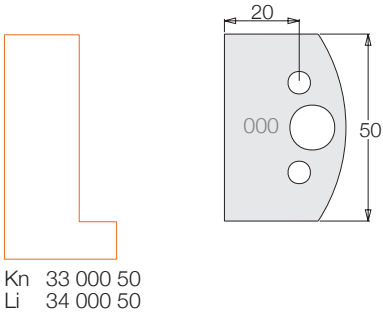

Sawing



CNC



Cutting

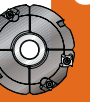

Drilling



Routing



Custom Tooling



Cutting

Multi Profile System - 50mm

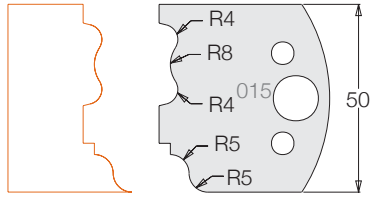

Kn 33 015 50
Li 34 015 50

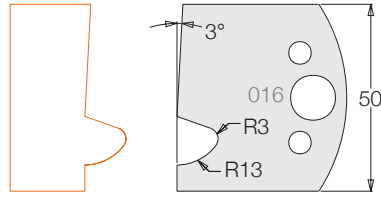

Kn 33 016 50
Li 34 016 50

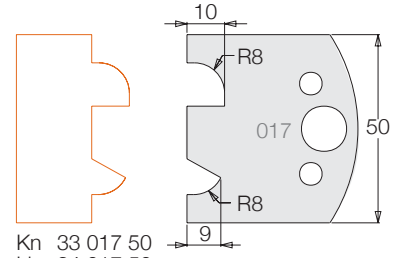

Kn 33 017 50
Li 34 017 50

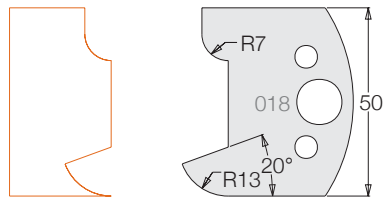

Kn 33 018 50
Li 34 018 50

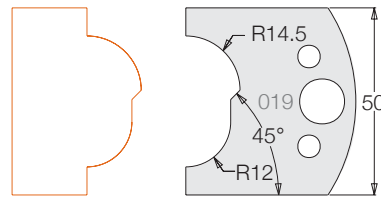

Kn 33 019 50
Li 34 019 50

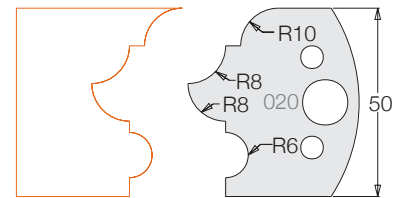

Kn 33 020 50
Li 34 020 50

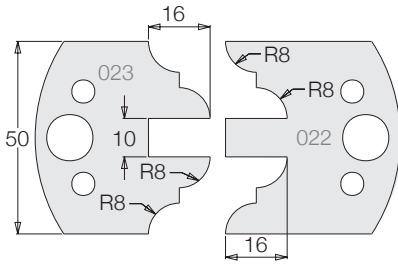

Kn 33 023 50
Li 34 023 50

Kn 33 022 50
Li 34 022 50

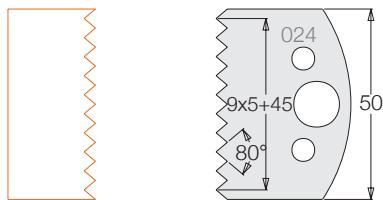

Kn 33 024 50
Li 34 024 50

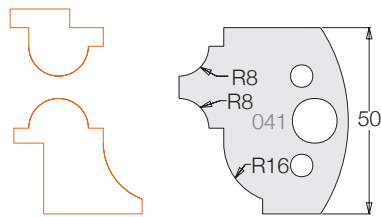

Kn 33 041 50
Li 34 041 50

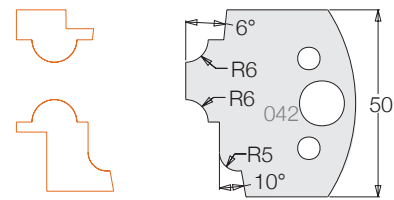

Kn 33 042 50
Li 34 042 50

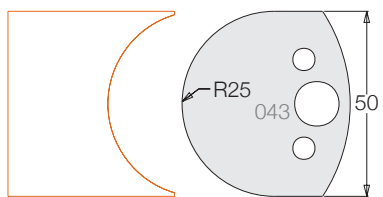

Kn 33 043 50
Li 34 043 50



Kn 33 044 50
Li 34 044 50

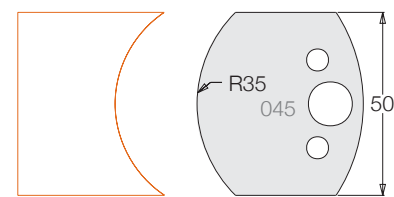

Kn 33 045 50
Li 34 045 50

Cutting

Multi Profile System - 50mm

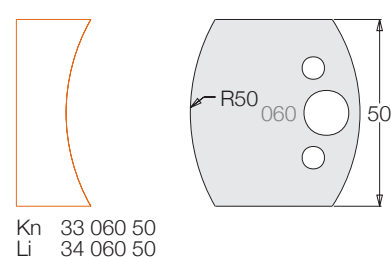
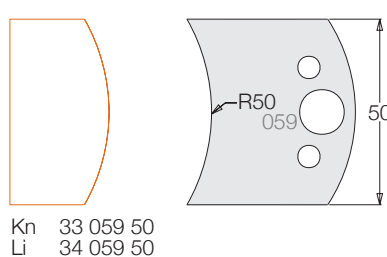
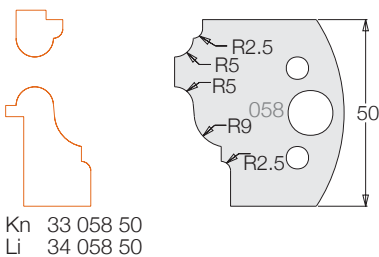
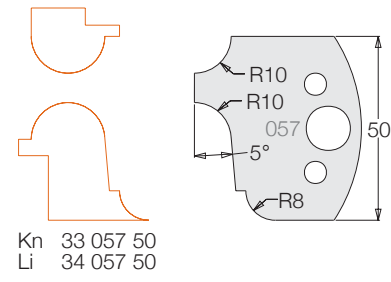
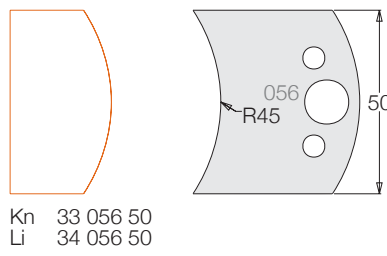
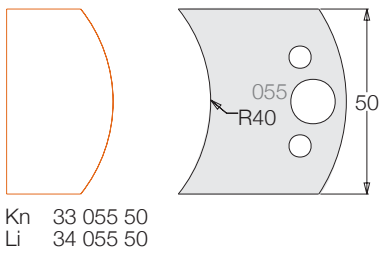
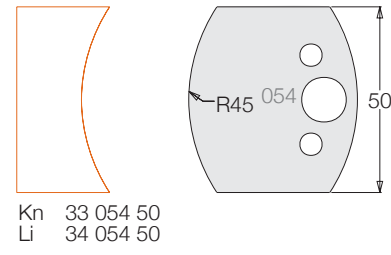
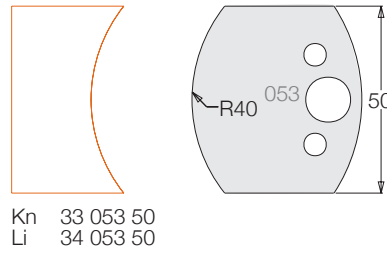
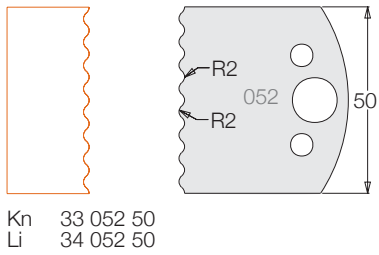
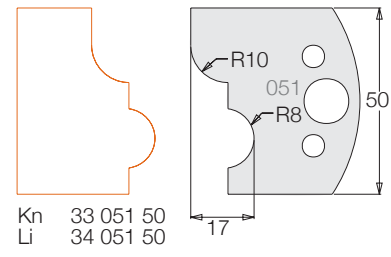
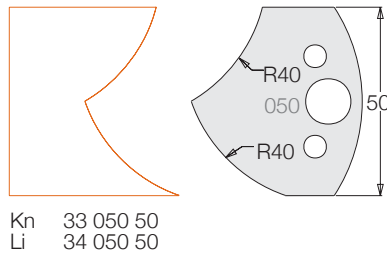
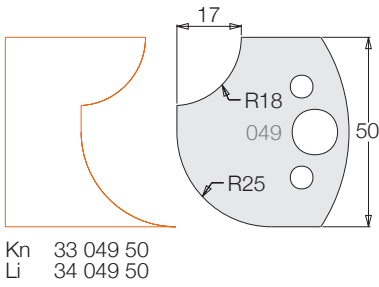
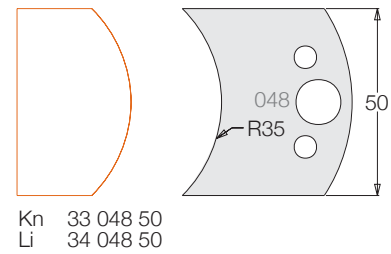
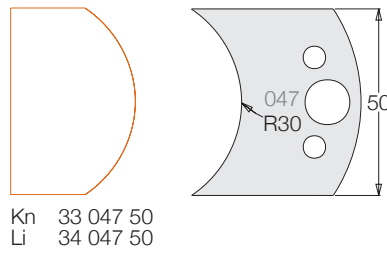
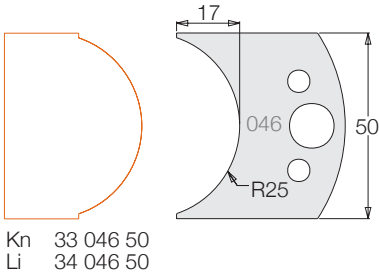

Cutting

Multi Profile System - 50mm

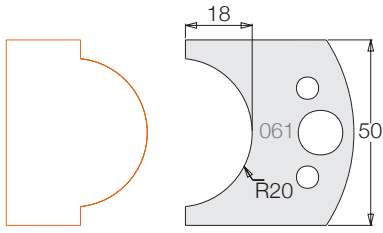

Kn 33 061 50
Li 34 061 50

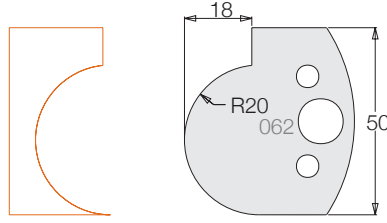

Kn 33 062 50
Li 34 062 50

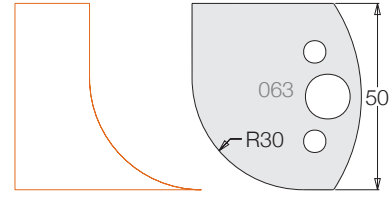

Kn 33 063 50
Li 34 063 50

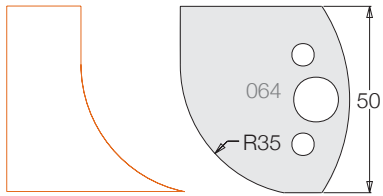

Kn 33 064 50
Li 34 064 50

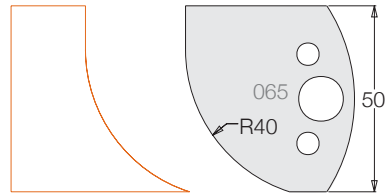

Kn 33 065 50
Li 34 065 50

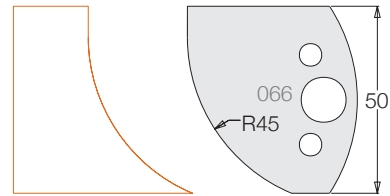

Kn 33 066 50
Li 34 066 50

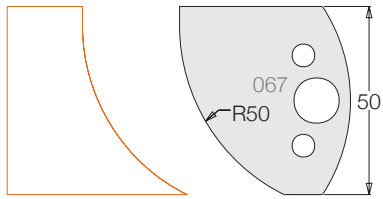

Kn 33 067 50
Li 34 067 50

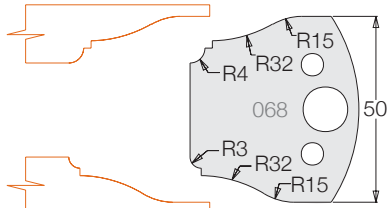

Kn 33 068 50
Li 34 068 50

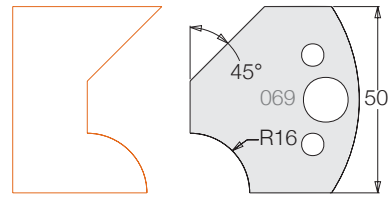

Kn 33 069 50
Li 34 069 50

