

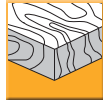

# Sawing

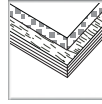

Solid Wood



Boards



Plastic

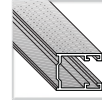

Aluminium

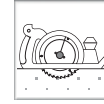

Saw blade for Portable Machines

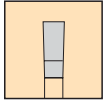

## MF - Rip Saw Blade

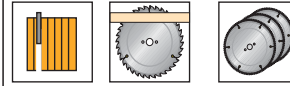
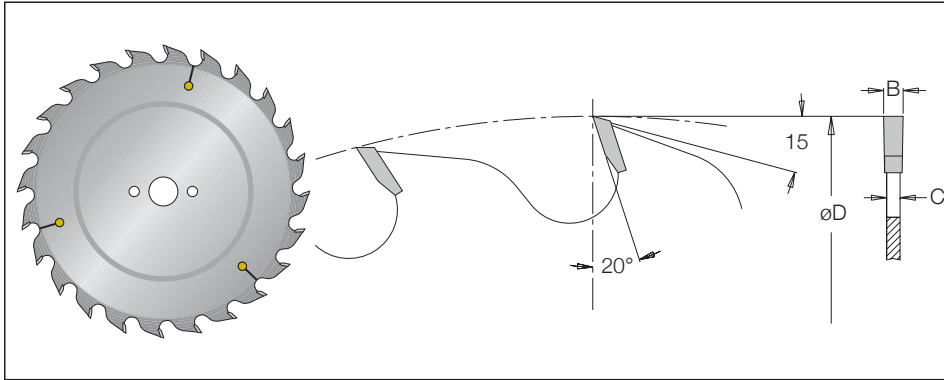

øD	Teeth	Code No.	B	c	☐	n	m/min	ød
200	14	901 00 20 6	3	2	-	5700-9000	12-19	30
250	20	901 00 30 6	3.2	2.2	-	4500-7600	14-23	30
	24	901 00 40 6	3.2	2.2	-	4500-7600	16-27	30
300	24	901 00 50 6	3.2	2.2	-	3800-6300	14-23	30
	30	901 00 60 6	3.2	2.2	-	3800-6300	17-28	30
350	28	901 00 70 6	3.5	2.5	-	3200-5400	13-23	30
400	32	901 00 80 6	3.5	2.5	-	2800-4500	13-22	30
450	32	901 00 84 6	4	2.8	-	2500-4000	12-19	30
500	36	901 00 85 6	4.4	3	-	2200-3500	12-19	30

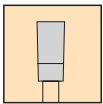

## MFT - Rip Saw Blade

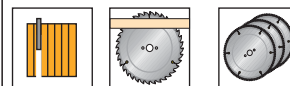
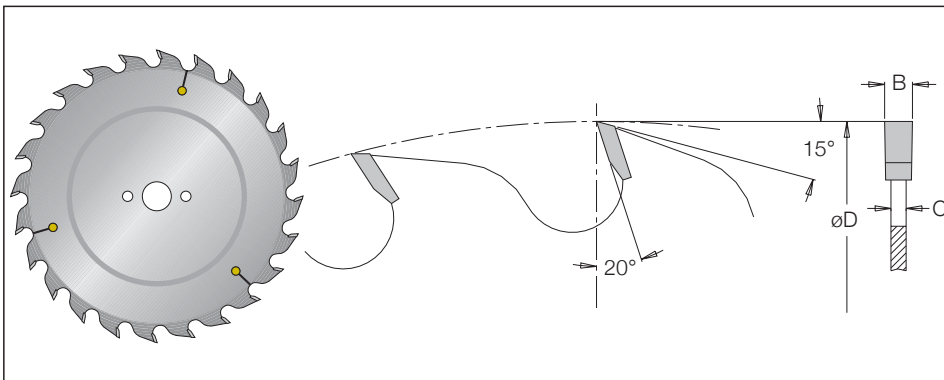

øD	Teeth	Code No.	B	c	n	m/min	ød
300	24	901 20 20 6	4	2.8	3800-6300	14-23	30
	24	901 20 30 6	4.4	2.8	3800-6300	14-23	30
350	28	901 20 60 6	4	2.8	3200-5400	13-23	30
	28	901 20 50 6	4.4	2.8	3200-5400	13-23	30
400	32	901 21 10 6	4	3	2800-4500	13-22	30
	32	901 20 90 6	4.4	3	2800-4500	13-22	30

Index

Sawing

CNC

Cutting

Drilling

Routing

Custom Tooling

# Sawing

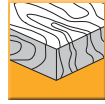

Solid Wood

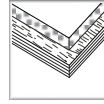

Boards



Plastic

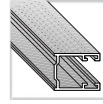

Aluminium

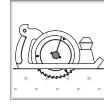

Saw blade for Portable Machines

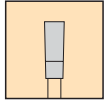

## MFG - Rip Saw Blade

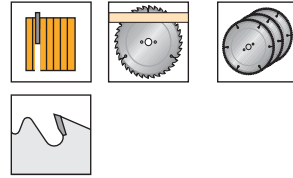
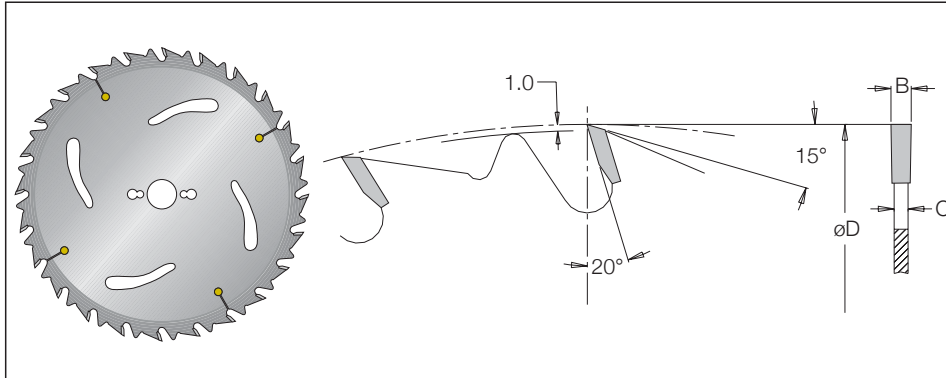

øD	Teeth	Code No.	B	c	☐	n	m/min	ød
250	20	901 00 90 6	3.2	2.2	-	4500-7600	14-23	30
	24	901 00 95 6	3.2	2.2	-	4500-7600	16-27	30
	14	901 00 97 6	3.2	2.2	-	3800-6300	8-13	30
300	24	901 01 00 6	3.2	2.2	-	3800-6300	14-23	30
	24	901 01 00 0	3.2	2.2	2/20x6	3800-6300	14-23	70
	28	901 01 04 6	3.2	2.2	-	3800-6300	16-26	30
	28	901 01 04 0	3.2	2.2	2/20x6	3800-6300	16-26	70
350	16	901 01 07 6	3.5	2.5	-	3200-5400	8-13	30
	28	901 01 10 6	3.5	2.5	-	3200-5400	13-23	30
	32	901 01 13 6	3.5	2.5	-	3200-5400	15-26	30
400	18	901 01 14 6	3.5	2.5	-	2800-4500	8-12	30
	28	901 01 15 6	3.5	2.5	-	2800-4500	12-19	30
450	40	901 01 16 6	4	2.8	-	2500-4000	15-24	30
500	44	901 01 18 6	4.4	3	-	2200-3500	15-23	30

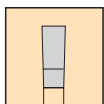

## SF - Rip Saw Blade - Special for Wet Solid Wood

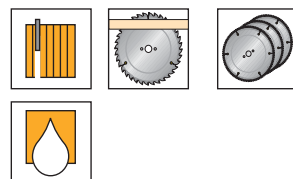
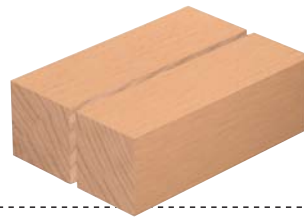
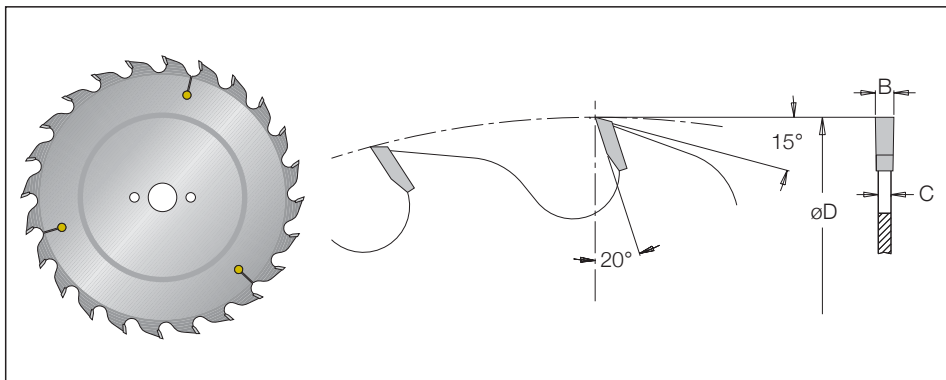

øD	Teeth	Code No.	B	c	☐	n	m/min	ød
250	24	910 00 40 6	3.2	2.2	-	4500-7600	16-27	30
	24	910 00 50 6	3.2	2.2	-	3800-6300	14-23	30
300	24	910 00 50 0	3.2	2.2	2/2x6	3800-6300	14-23	70
350	28	910 00 70 6	3.5	2.5	-	3200-5400	13-23	30
400	32	910 00 80 6	3.5	2.5	-	2800-4500	13-22	30

⚠ A special carbide - suitable to work with wet wood.



# Sawing

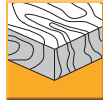

Solid Wood

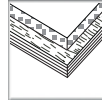

Boards



Plastic

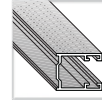

Aluminium

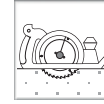

Saw blade for Portable Machines

Index

Sawing

CNC

Cutting

Drilling

Routing

Custom Tooling

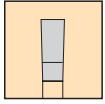

## SFG - Rip Saw Blade - Special for Wet Solid Wood

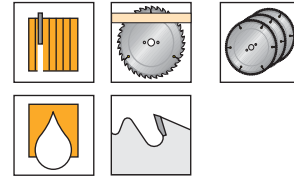
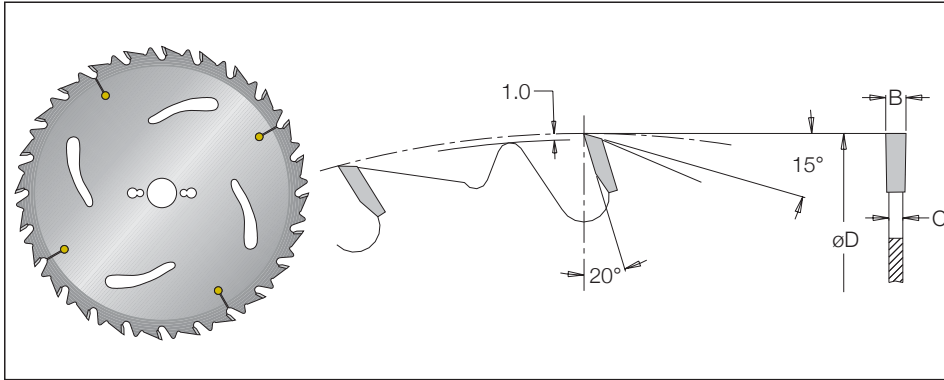

øD	Teeth	Code No.	B	c	⊕	n	m/min	ød
250	24	910 00 95 6	3.2	2.2		4500-7600	16-27	30
	24	910 01 00 6	3.2	2.2		3800-6300	14-23	30
300	24	910 01 00 0	3.2	2.2	2/20x6	3800-6300	14-23	70
350	28	910 01 10 6	3.5	2.5		3200-5400	13-23	30
400	28	910 01 15 6	3.5	2.5		2800-4500	12-19	30

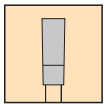

## MFM - Multi Rip Saw Blade

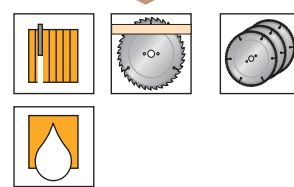
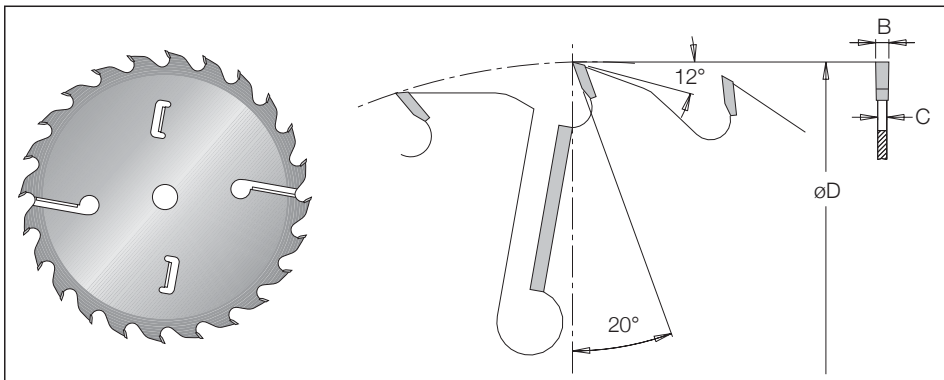

øD	Teeth	Code No.	B	c	⊕	n	m/min	ød
250	18+2	904 00 10 0	3.2	2.2	2/20x6	4500-7600	12-21	70*
300	20+2+2	904 00 30 0	3.2	2.2	2/20x6	3800-6300	11-19	70*
350	24+2+2	904 00 50 0	3.5	2.5	2/20x6	3200-5400	12-19	70

⚠ Wet and dry wood.  
 \* Can also be supplied with 30 mm bore.  
 With rakers to prevent the wood from making contact with the saw body.



# Sawing

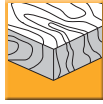

Solid Wood

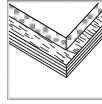

Boards

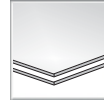

Plastic

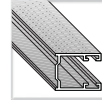

Aluminium

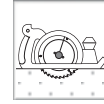

Saw blade for Portable Machines

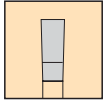

## MFGM - Rip Saw Blade

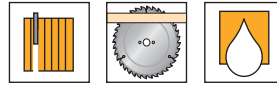
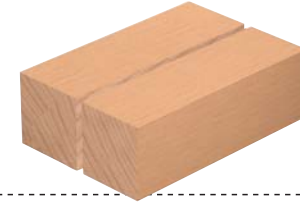
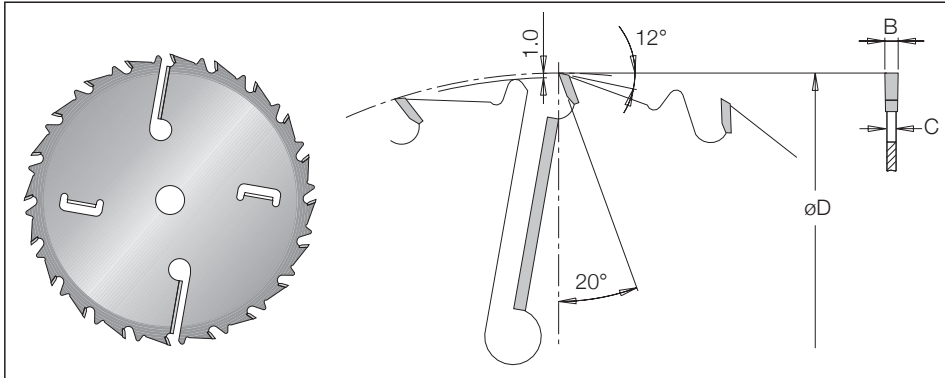

øD	Teeth	Code No.	B	c	n	m/min	ød
300	20+2+2	904 00 35 6	3.2	2.2	3800-6300	11-19	30
350	24+2+2	904 00 55 6	3.5	2.5	3200-5400	12-19	30

⚠ With rakers to prevent the wood from making contact with the saw body.

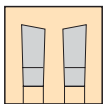

## MWO - Cross Cut Saw Blade

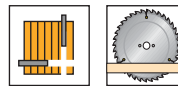
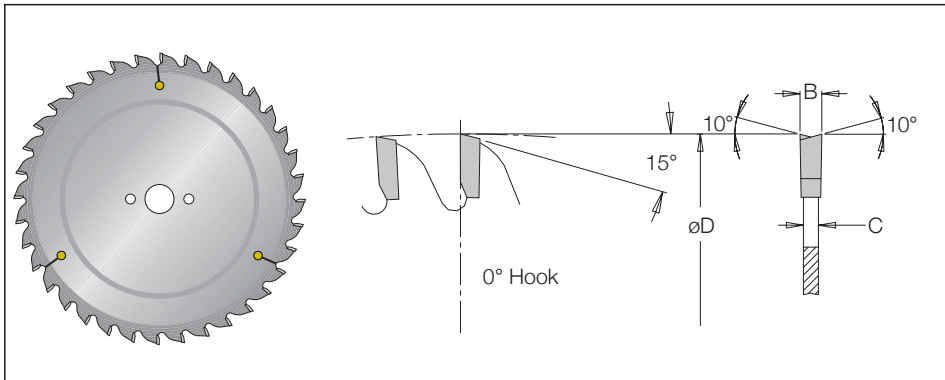

øD	Teeth	Code No.	B	c	n	m/min	ød
250	24	908 01 10 6	3.4	2.4	4500-7600	16-27	30
	42	908 01 20 6	3.4	2.4	4500-7600	28-48	30
300	36	908 01 30 6	3.8	2.8	3800-6300	21-34	30
350	42	908 01 50 6	4.2	2.8	3200-5400	20-34	30
400	48	908 01 70 6	4.2	3	2800-4500	20-32	30

⚠ Meant for over arm machine.