

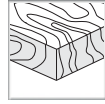

Sawing

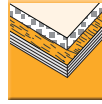

Solid Wood



Boards



Plastic

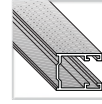

Aluminium

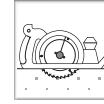

Saw blade for Portable Machines

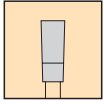

DFH - Hoggers Saw Blades, Extended Life

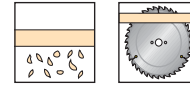
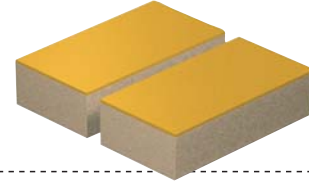
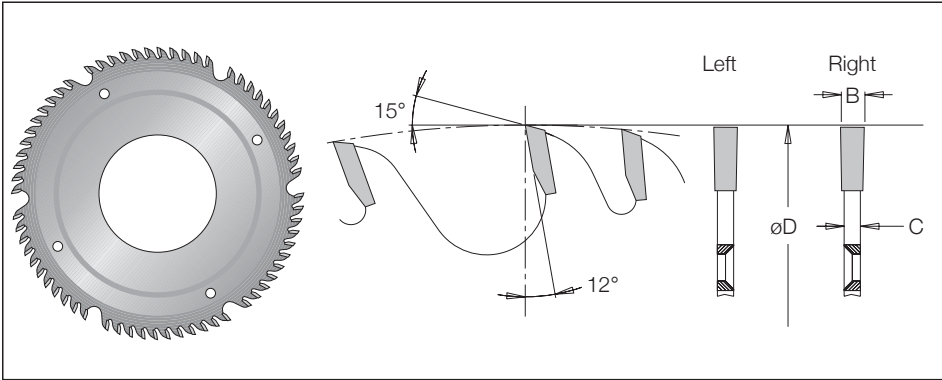

øD	Teeth	Code No.		B	c	n	m/min	ød	PH
		Right	Left						
180	54	957 01 00 S*	957 01 05 S*	3.2	2.2	5300-8400	49-77	65	6 / 6.5 / 90
	54	957 01 03 N*		3.2	2.2	5300-8400	49-77	50	3 / 22 / 80
200	40	957 01 10 U	957 01 15 U	4	2.8	4700-7600	32-52	80	4 / 6.5 / 140
	60	957 01 20 U	957 01 25 U	4	2.8	4700-7600	48-78	80	4 / 6.5 / 140
	60	957 01 21 U	957 01 26 U	4	2.8	4700-7600	48-78	80	8 / 6.5 / 155
	48	957 01 30 U	957 01 35 U	4	2.8	3800-6100	31-50	80	6 / 6.5 / 200
250	48	957 01 30 Z	957 01 35 Z	4	2.8	3800-6100	31-50	100	6 / 6.5 / 200
	72	957 01 40 U	957 01 45 U	4	2.8	3800-6100	47-75	80	6 / 6.5 / 200
	72	957 01 40 Z	957 01 45 Z	4	2.8	3800-6100	47-75	100	6 / 6.5 / 200

⚠ * Scoring for hogging.

Segment for Hogger

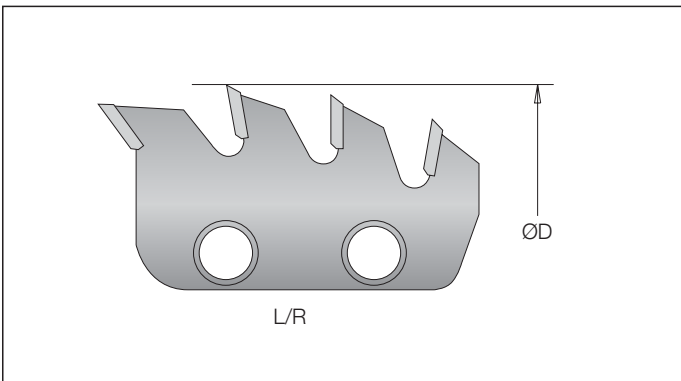

Teeth	Code No.	L/R	Suitable to segmented hogger diameter 200/250mm.
4	911 08 10 4	L/R	

Index

Sawing

CNC

Cutting

Drilling

Routing

Custom Tooling