

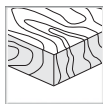

# Sawing



Solid Wood



Boards

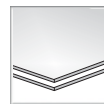

Plastic



Aluminium

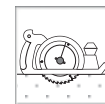

Saw blade for Portable Machines

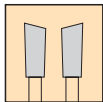

## DWT - Main Saw for Panel Sizing Boards Extended Life

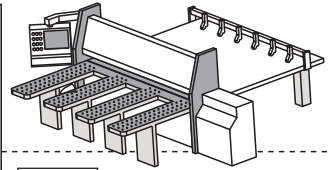
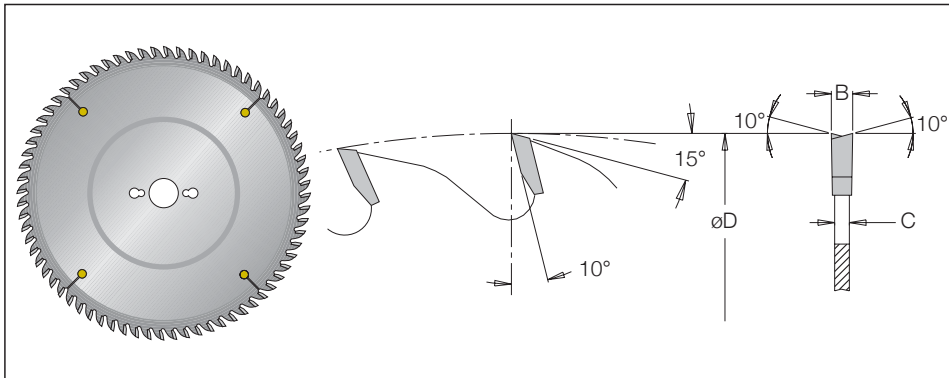

Type	øD	Teeth	Code No.	B/C	ød	NI
Mayer/	305	48	955 110 06	4.4/3.0	30	
	305	60	955 110 56	4.4/3.0	30	
	355	54	955 111 06	4.4/3.0	30	
	355	72	955 111 56	4.4/3.0	30	
Giben	355	54	955 111 0T	4.4/3.0	75	
	355	72	955 111 5T	4.4/3.0	75	
	400	72	955 113 0T	4.4/3.2	75	4/15/105
	430	54	955 114 5T	4.4/3.2	75	4/15/105
	430	72	955 115 0T	4.4/3.2	75	4/15/105
Scm/	400	72	955 113 0U	4.4/3.2	80	4/9/100
Gabbiani						2/14/110
						2/7/110
Holzma	400	72	955 113 0R	4.4/3.2	60	
	420	72	955 114 0R	4.8/3.5	60	
	450	72	955 117 0R	4.8/3.5	60	2/14/125
Schelling	400	60	955 112 56	4.4/3.2	30	
Anton	400	72	955 113 0R	4.4/3.2	60	
Teutomatik	500	60	955 118 0U	4.4/3.2	80	

Manufacturing Technology:



Dynamic Balancing



Dynamic Straightness

Index

Sawing

CNC

Cutting

Drilling

Routing

Custom Tooling



# Sawing

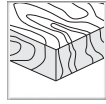

Solid Wood

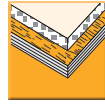

Boards

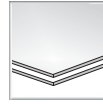

Plastic

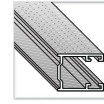

Aluminium

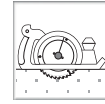

Saw blade for  
Portable  
Machines

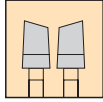

## DVK - Conic Scoring Saw, Extended Life

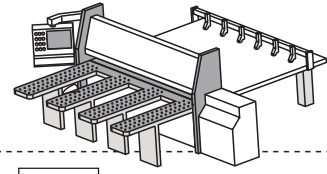
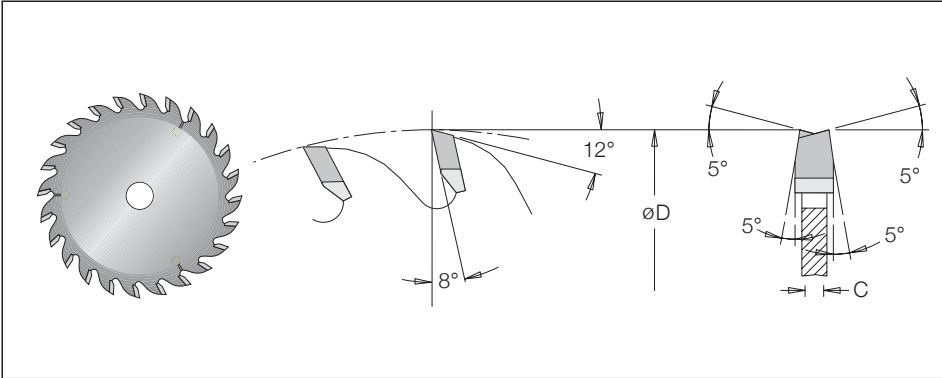

øD	Teeth	Code No	B	C	ød	NI
125	24	95600793	4.4-5.3	3.2	20	
125	24	95600793	4.4-5.3	3.2	20	
125	24	95600793	4.4-5.3	3.2	20	
125	24	95600793	4.4-5.3	3.2	20	
125	24	9560079M	4.4-5.3	3.2	45	
125	24	9560079M	4.4-5.3	3.2	45	
160	36	9560195M	4.4-5.3	3.2	45	3/11/70
216	42	9560270N	4.4-5.3	3.2	50	3/15/80
216	42	9560270N	4.4-5.3	3.2	50	3/15/80
125	24	9560079M	4.4-5.3	3.2	45	
160	36	9560195C	4.4-5.3	3.2	55	3/7/66
150	24	95600883	4.4-5.3	3.2	20	
180	30	95602103	4.4-5.3	3.2	20	



# Sawing

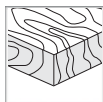

Solid Wood

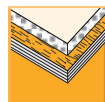

Boards

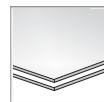

Plastic

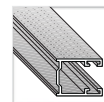

Aluminium



Saw blade for Portable Machines

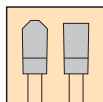

## DST - Main Saw for Panel Sizing Laminated Boards Extended Life

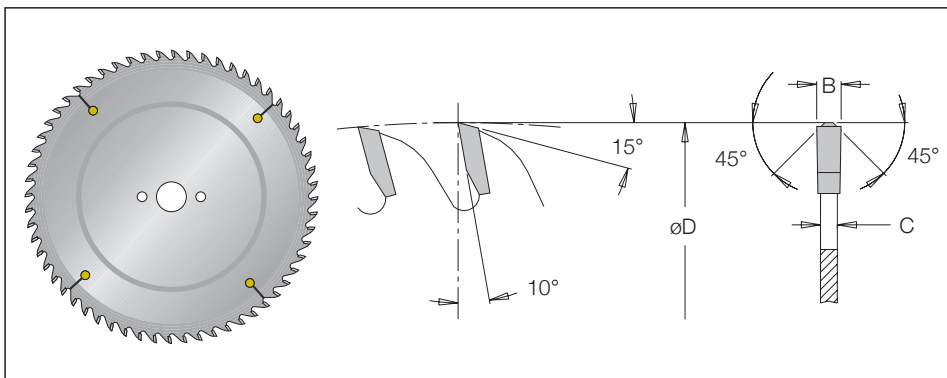

Type	øD	Teeth	Code No.	B/C	ød	NI
Scher	400	72	95531296	4.25/3.2	30	NI
Panhans	305	60	95531056	4.4/3.0	30	
	355	54	95531106	4.4/3.0	30	
	355	72	95531156	4.4/3.0	30	
Giben	355	54	9553110T	4.4/3.0	75	
	355	72	9553115T	4.4/3.0	75	
	400	60	9553125T	4.4/3.2	75	4/15/105
	400	72	9553130T	4.4/3.2	75	4/15/105
	430	72	9553150T	4.4/3.2	75	4/15/105
	430	96	9553155T	4.4/3.2	75	4/15/105
	470	96	9553175T	4.4/3.2	75	4/15/105
Scm	500	72	9553190T	4.4/3.2	75	
	500	72	9553195T	4.8/3.5	75	
	500	72	9553200T	5/3.5	75	
	550	72	9553230Z	5/3.5	100	
	305	60	9553105U	4.4	80	2/14/110
Gabbiani	380	72	9553123U	4.8	80	2/14/110
	420	72	9553135U	4.4	80	2/14/110
	355	72	9553115U	4.4/3.0	80	4/9/100/2/14/110/2/7100
Holzma	380	72	9553123R	4.8/3.5	60	2/14/100
	400	72	9553130R	4.4/3.2	60	
	420	72	9553135R	4.4/3.2	60	2/14/125-2/10/80
	420	72	9553140R	4.8/3.5	60	2/14/125-2/10/80
	450	72	9553160R	4.4/3.2	60	2/14/125-2/10/80
	450	72	9553170R	4.8/3.5	60	2/14/125-2/10/80
	500	60	9553185R	4.8/3.5	60	2/11/115
	500	72	9553195R	4.8/3.5	60	2/11/115
	500	72	9553200R	5/3.5	60	
	520	72	9553205R	4.8/3.5	60	2/11/115-2/19/120
Schelling	600	72	9553301R	5.8/4.0	60	2/19/120-2/11/115
	355	72	95531156	4.4/3.2	30	
	400	60	95531256	4.4/3.2	30	



Dynamic Balancing



Dynamic Straightness

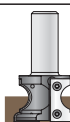

Custom Tooling

# Sawing

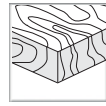

Solid Wood

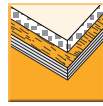

Boards

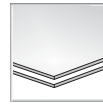

Plastic

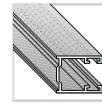

Aluminium

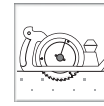

Saw blade for Portable Machines

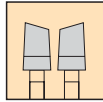

## DVK - Conic Scoring Saw, Extended Life

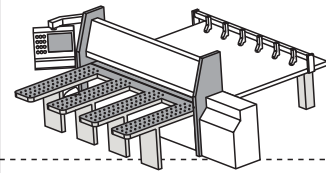
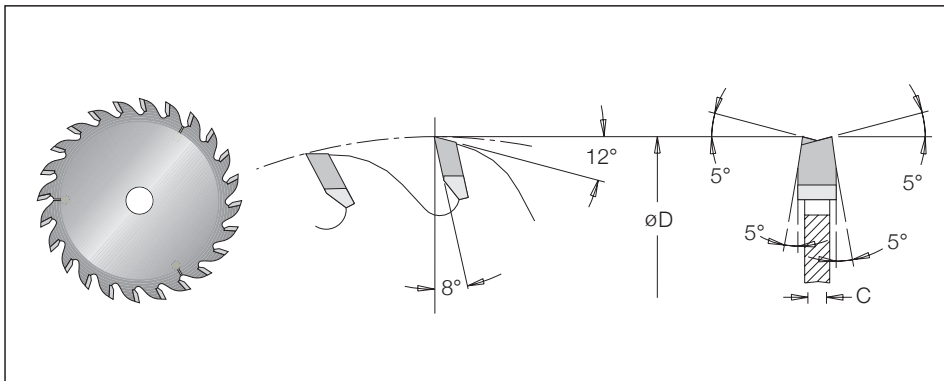

øD	Teeth	Code No	B	C	ød	Nl	Grinding type
400	72	95531306	4.4	3.2	30		2
125	24	95600793	4.4-5.3	3.2	20		3
125	24	95600793	4.4-5.3	3.2	20		3
125	24	95600793	4.4-5.3	3.2	20		3
125	24	9560079M	4.4-5.3	3.2	45		3
125	24	9560079M	4.4-5.3	3.2	45		3
160	36	9560195M	4.4-5.3	3.2	45	3/11/70	3
160	36	9560195M	4.4-5.3	3.2	45	3/11/70	3
216	42	9560270N	4.4-5.3	3.2	50	3/15/80	3
300	48	9560280N	4.4-5.3	3.2	50	3/15/80	3
216	42	9560270N	4.4-5.3	3.2	50	3/15/80	3
300	48	9560280N	4.4-5.3	3.2	50	3/15/80	3
216	42	9560270N	4.4-5.3	3.2	50	3/15/80	3
300	48	9560280N	4.4-5.3	3.2	50	3/15/80	3
125	24	9560079M	4.4-5.3	3.2	45		3
180	30	9560215C	5-6.3	3.5	55		3
160	36	9560195C	4.4		55	3/7/66	3
200	36	9560261U	4.8		80	2/14/110	3
160	36		4.8		55	3/7/66	3
200	36	9560261U	4.4		80	2/14/110	3
160	36	9560195C	4.4		55	3/7/66	3
160	36	9560195C	4.4-5.3	3.2	55	3/7/66	3
200	36	9560265M	4.4		45		3
200	36	9560261M	4.8-6.0	3.5	45		3
180	30	9560216M	4.8-6.0	3.5	45		3
180	30	9560216M	4.8-6.0	3.5	45		3
340	108	9551109M	5	3.5	45		1
200	36	9560261M	4.8-6.0	3.5	45		3
340	108	9551109M	5	3.5	45		1
200	36	9560261M	4.8-6.0	3.5	45		3
340	108	9551109M	5	3.5	45		1
200	36	9560261M	4.8-6.0	3.5	45		3
340	108	9551109M	5	3.5	45		1
200	36	9560268M	5.8-6.6	4.2	45		3
200	36	95602653	4.4-5.3	3.2	20		3
150	24	95600883	4.4-5.3	3.2	20		3



# Sawing

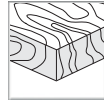

Solid Wood

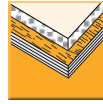

Boards

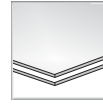

Plastic

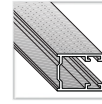

Aluminium

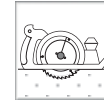

Saw blade for Portable Machines



## DST - Main Saw for Panel Sizing Laminated Boards Extended Life

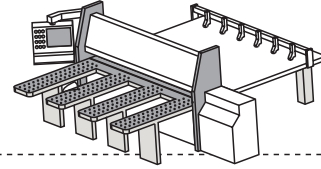
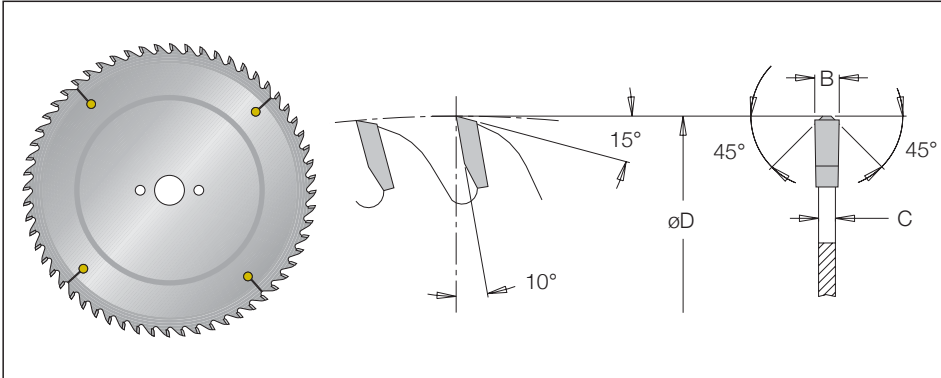

Type	øD	Teeth	Code No.	B/C	ød	NI
Schelling	400	72	95531306	4.4/3.2	30	
	450	72	95531606	4.4/3.2	30	
	480	72	95531776	4.4/3.2	30	
	500	72	95531906	4.4/3.2	30	
Anthon	400	72	9553130R	4.4/3.2	60	2/11/85
	430	72	9553150R	4.4/3.2	60	2/11/85
	530	60	9553220R	5.8/4.0	60	2/11/85
Selco	320	72	9553104S	4.4/3.2	65	2/9/110-2/9/100
	300	60	9553350S	4.4/3.2	65	2/9/110
	355	72	9553116U	4.4/3.2	80	4/19/120-2/9/130
	380	72	9553121U	4.4/3.2	80	4/19/120-2/9/130
	400	72	9553132U	4.4/3.2	80	4/19/120-2/9/130
	430	72	9553150U	4.4/3.2	80	4/19/120-2/9/130
	450	72	9553160U	4.4/3.2	80	4/19/120-2/9/130
	450	72	9553170U	4.8/3.5	80	4/19/120-2/9/130
	480	72	9553178U	4.8/3.5	80	4/19/120-2/9/130
	Mayer	305	60	95531056	4.4/3.0	30
355		54	95531106	4.4/3.0	30	
355		72	95531156	4.4/3.0	30	
400		72	95531306	4.4/3.0	30	
S.m.a	355	72	9553115U	4.4/3.0	80	4/9/100/2/7/110/2/9/130

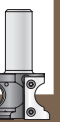
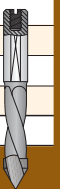
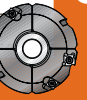

Manufacturing Technology:



Dynamic Balancing



Dynamic Straightness

# Sawing

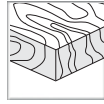

Solid Wood

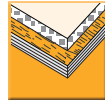

Boards

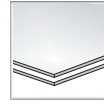

Plastic

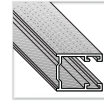

Aluminium

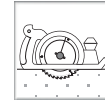

Saw blade for  
Portable  
Machines

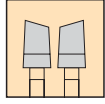

## DVK - Conic Scoring Saw, Extended Life

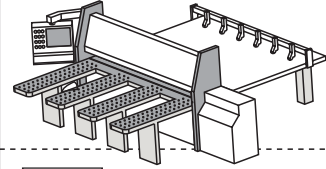
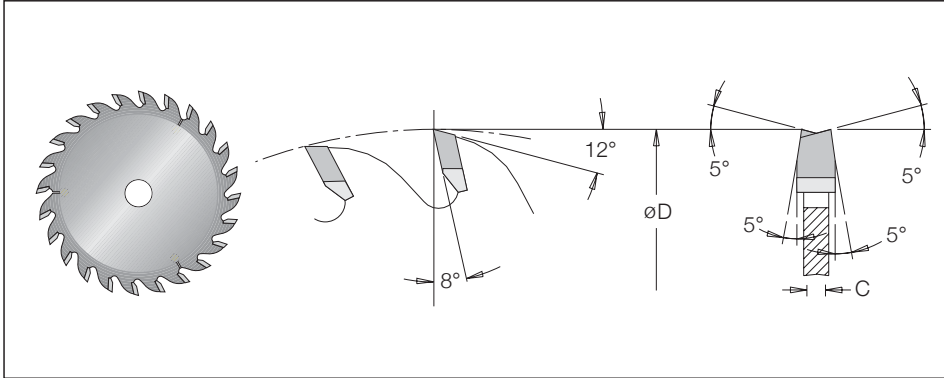

øD	Teeth	Code No	B	C	ød	NI	Grinding type
150	24	95600883	4.4-5.3	3.2	20		3
200	36	95602653	4.4-5.3	3.2	20		3
200	36	95602653	4.4-5.3	3.2	20		3
200	36	95602653	4.4-5.3	3.2	20		3
180	30	95602103	4.4-5.3	3.2	20		3
180	30	95602103	4.4-5.3	3.2	20		3
180	30	95602203	5.8-7.8	4	20		3
200	36	9560265S	4.4-5.3	3.2	65	2/9/110	3
200	36	9560265S	4.4-5.3	3.2	65	2/9/110	3
300	72	9551106S	4.6	3.2	65	2/9/110	1
200	36	9560265S	4.4-5.3	3.2	65	2/9/110	3
300	72	9551106S	4.6	3.2	65	2/9/110	1
200	36	9560265S	4.4-5.3	3.2	65	2/9/110	3
300	72	9551106S	4.6	3.2	65	2/9/110	1
200	36	9560265S	4.4-5.3	3.2	65	2/9/110	3
300	72	9551106S	4.6	3.2	65	2/9/110	1
200	36	9560265S	4.4-5.3	3.2	65	2/9/110	3
300	72	9551106S	4.6	3.2	65	2/9/110	1
200	36	9560261S	4.8-6.0	3.5	65	2/9/110	3
200	36	9560261S	4.8-6.0	3.5	65	2/9/110	3